

REVISIONS

LTR	DESCRIPTION	DATE (YR-MO-DA)	APPROVED
F	Added cage code for device types 01, 02, 04, 06, 07, 08, 09, and 10. Added device types 11 and 12 with cage code 88379. Added figures 7 and 8. Editorial changes throughout.	95-12-06	K. Cottongim
G	Updated drawing to the latest requirements. -sld	05-05-19	Raymond Monnin
H	Added class K level for device types 06, 07, and 09. -sld	08-03-21	Robert M. Heber

REV																				
SHEET																				
REV	H	H	H	H	H	H	H	H												
SHEET	15	16	17	18	19	20	21	22												
REV STATUS OF SHEETS	REV			H	H	H	H	H	H	H	H	H	H	H	H	H	H	H	H	H
	SHEET			1	2	3	4	5	6	7	8	9	10	11	12	13	14			

PMIC N/A	PREPARED BY Steve L. Duncan	<p align="center">DEFENSE SUPPLY CENTER COLUMBUS COLUMBUS, OHIO 43218-3990 http://www.dsccl.dla.mil/</p>																		
<p align="center">STANDARD MICROCIRCUIT DRAWING</p> <p align="center">THIS DRAWING IS AVAILABLE FOR USE BY ALL DEPARTMENTS AND AGENCIES OF THE DEPARTMENT OF DEFENSE</p> <p align="center">AMSC N/A</p>	CHECKED BY Micheal C. Jones																			
	APPROVED BY Kendall A. Cottongim	<p align="center">MICROCIRCUIT, HYBRID ,DIGITAL, DUAL CHANNEL, DRIVER-RECEIVER</p>																		
	DRAWING APPROVAL DATE 89-05-08																			
	REVISION LEVEL H		<table border="1"> <tr> <td>SIZE A</td> <td>CAGE CODE 67268</td> <td>5962-89522</td> </tr> </table>	SIZE A	CAGE CODE 67268	5962-89522														
SIZE A	CAGE CODE 67268	5962-89522																		
		SHEET	1 OF 22																	

1. SCOPE

1.1 Scope. This drawing describes device requirements for class H hybrid microcircuits to processed in accordance with MIL-PRF-38534.

1.2 PIN. The PIN shall be as shown in the following example:

For class H devices:

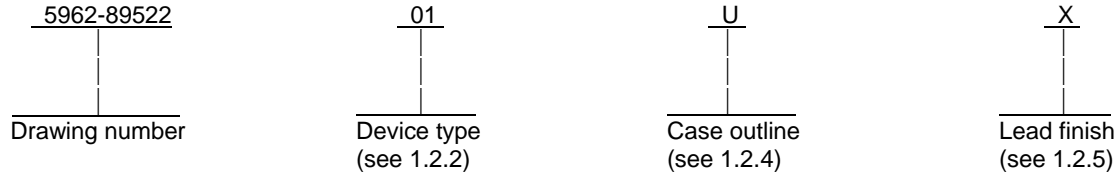

For class K devices:

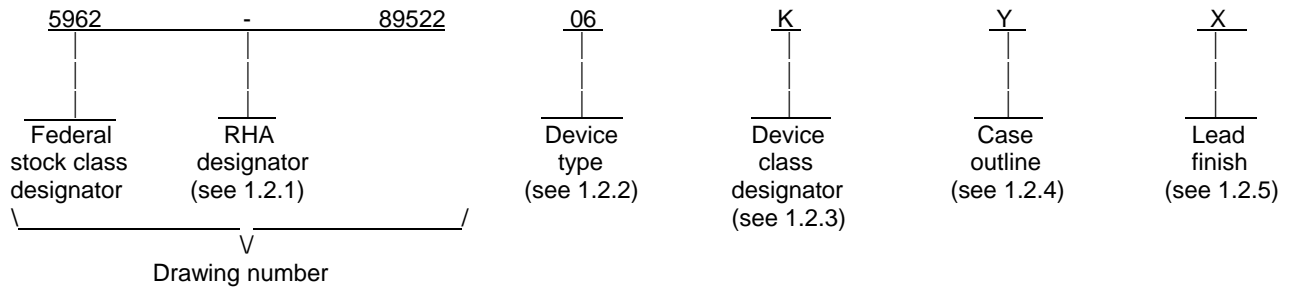

1.2.1 Radiation hardness assurance (RHA) designator. Device classes H and K RHA marked devices shall meet the MIL-PRF-38534 specified RHA levels and shall be marked with the appropriate RHA designator. A dash (-) indicates a non-RHA device.

1.2.2 Device type(s). The device type(s) identify the circuit function as follows:

Device type	Generic number	Circuit function	Coupling transformer turns ratio	
			transformer	direct
01	NHI-1559	Dual channel, five volt, MIL-STD-1553 transceiver	4:7	2:5
02	2453,NHI-1529	Dual channel, five volt, MIL-STD-1553 transceiver	1:1.5	1:2.12
03	NHI-1529	Dual channel, five volt, MIL-STD-1553, transceiver	1:1.5	1:2.12
04	NHI-1559	Dual channel, five volt, MIL-STD-1553, transceiver ^{1/}	4:7	2:5
05	CT2521	Dual channel, five volt, MIL-STD-1553, transceiver	1:1.5	1:2.12
06	FC1552921,NHI-1529	Dual channel, five volt, MIL-STD-1553, transceiver	1:1.5	1:2.12
07	FC1553923,NHI-1559	Dual channel, five volt, MIL-STD-1553, transceiver ^{1/}	4:7	2:5
08	3453,NHI-1529	Dual channel, five volt, MIL-STD-1553, transceiver	1:1.5	1:2.12
09	FC1553922,NHI-1529	Dual channel, five volt, MIL-STD-1553, transceiver	1:1.5	1:2.12

^{1/} Device types 04 and 07 are compatible with ILC/DDC BUS-65612 protocol.

STANDARD MICROCIRCUIT DRAWING DEFENSE SUPPLY CENTER COLUMBUS COLUMBUS, OHIO 43218-3990	SIZE A		5962-89522
		REVISION LEVEL H	SHEET 2

<u>Device type</u>	<u>Generic number</u>	<u>Circuit function</u>	<u>Coupling transformer</u>	
			<u>turns ratio</u>	<u>transformer direct</u>
10	FC1553924,NHI-1559	Dual channel, five volt, MIL-STD-1553, transceiver <u>1/</u>	4:7	2:5
11	ACT-4453-001-6	Dual channel, five volt, MIL-STD-1553, transceiver	1:1.5	1:2.12 or 1:1.77 1:2.5
12	ACT-4453-001-3	Dual channel, five volt, MIL-STD-1553, transceiver	1:1.5	1:2.12 or 1:1.77 1:2.5

1.2.3 Device class designator. This device class designator shall be a single letter identifying the product assurance level. All levels are defined by the requirements of MIL-PRF-38534 and require QML Certification as well as qualification (Class H, K, and E) or QML Listing (Class G and D). The product assurance levels are as follows:

<u>Device class</u>	<u>Device performance documentation</u>
K	Highest reliability class available. This level is intended for use in space applications.
H	Standard military quality class level. This level is intended for use in applications where non-space high reliability devices are required.
G	Reduced testing version of the standard military quality class. This level uses the Class H screening and In-Process Inspections with a possible limited temperature range, manufacturer specified incoming flow, and the manufacturer guarantees (but may not test) periodic and conformance inspections (Group A, B, C, and D).
E	Designates devices which are based upon one of the other classes (K, H, or G) with exception(s) taken to the requirements of that class. These exception(s) must be specified in the device acquisition document; therefore the acquisition document should be reviewed to ensure that the exception(s) taken will not adversely affect system performance.
D	Manufacturer specified quality class. Quality level is defined by the manufacturers internal, QML certified flow. This product may have a limited temperature range.

1.2.4 Case outline(s). The case outline(s) are as designated in MIL-STD-1835 and as follows:

<u>Outline letter</u>	<u>Descriptive designator</u>	<u>Terminals</u>	<u>Package style</u>
U	See figure 1	36	Flat Package
X	See figure 1	36	Dual-in-line
Y	See figure 1	36	Flat package
Z	See figure 1	36	Dual-in-line

1.2.5 Lead finish. The lead finish shall be as specified in MIL-PRF-38534.

1/ Device type 10 is compatible with ILC/DDC BUS-65612 protocol.

STANDARD MICROCIRCUIT DRAWING DEFENSE SUPPLY CENTER COLUMBUS COLUMBUS, OHIO 43218-3990	SIZE A		5962-89522
		REVISION LEVEL H	SHEET 3

1.3 Absolute maximum ratings. ^{1/}

Supply voltage range	-0.3 V dc to +7.0 V dc
Logic input voltage range.....	-0.3 V dc to +5.5 V dc
Receiver differential voltage:	
Device types 01, 02, 04, and 08	10 V _{p-p}
Device types 03 and 05.....	40 V _{p-p}
Device types 06, 07, 09, 10, 11, and 12	20 V _{p-p}
Receiver common mode voltage:	
Device types 01, 02, 04, 08, 11, and 12	±5.0 V dc
Device types 03, 05, 06, 07, 09, and 10	±10.0 V dc
Driver peak output current:	
Device types 01 through 10.....	800 mA
Device types 11 and 12.....	650 mA
Total package power dissipation over the full operating case temperature rise (device types 11 and 12)	1.3 W ^{2/}
Power dissipation (P _D):	
Hottest die (worse case):	
Device types 01-04, 06-09 and 10.....	320 mW
Device type 05.....	250 mW
Total hybrid-standby	495 mW
Total hybrid-100% duty cycle:	
Device types 01, 02, 04, 05, and 08	3.10 W
Device types 03, 11, and 12	0.95 W
Device types 06, 07, 09, and 10	1.55 W
Storage temperature range.....	-65°C to +150°C
Lead temperature (soldering, 10 seconds).....	+300°C
Thermal resistance, junction-to-case (θ _{JC}):	
Device types 01, 02, 04, 06, and 07-10	110°C/W (hottest die)
Device type 03.....	38.6°C/W (hottest die)
Device type 05.....	60°C/W
Device types 11 and 12	5°C/W
Thermal resistance, case-to-air (θ _{CA})	20°C/W
Junction temperature (T _J)	+175°C

1.4 Recommended operating conditions.

Supply voltage range	+4.75 V dc to +5.5 V dc
Logic input voltage range.....	0.0 V dc to +5.5 V dc
Receiver differential voltage:	
Device types 01, 02, 04, and 08	4.0 V _{p-p}
Device types 03, 05, 11, and 12	15.0 V _{p-p}
Device types 06, 07, 09, and 10	16.0 V _{p-p}
Receiver common-mode voltage:	
Device types 01, 02, 04, and 08	±2.5 V dc
Device types 03, 05, 11, and 12	±5.0 V dc
Device types 06, 07, 09, and 10	±10.0 V dc
Driver peak output current	700 mA
Serial data rate	1.0 MHz maximum
Case operating temperature range	-55°C to +125°C

^{1/} Stresses above the absolute maximum rating may cause permanent damage to the device. Extended operation at the maximum levels may degrade performance and affect reliability.

^{2/} Normal operating conditions require one transceiver on and the other off.

STANDARD MICROCIRCUIT DRAWING DEFENSE SUPPLY CENTER COLUMBUS COLUMBUS, OHIO 43218-3990	SIZE A		5962-89522
		REVISION LEVEL H	SHEET 4

2. APPLICABLE DOCUMENTS

2.1 Government specification, standards, and handbooks. The following specification, standards, and handbooks form a part of this drawing to the extent specified herein. Unless otherwise specified, the issues of these documents are those cited in the solicitation or contract.

DEPARTMENT OF DEFENSE SPECIFICATIONS

MIL-PRF-38534 - Hybrid Microcircuits, General Specification for.

DEPARTMENT OF DEFENSE STANDARDS

MIL-STD-883 - Test Method Standard Microcircuits.
MIL-STD-1835 - Interface Standard Electronic Component Case Outlines.

DEPARTMENT OF DEFENSE HANDBOOKS

MIL-HDBK-103 - List of Standard Microcircuit Drawings.
MIL-HDBK-780 - Standard Microcircuit Drawings.

(Copies of these documents are available online at <http://assist.daps.dla.mil/quicksearch/> or <http://assist.daps.dla.mil> or from the Standardization Document Order Desk, 700 Robbins Avenue, Building 4D, Philadelphia, PA 19111-5094.)

2.2 Order of precedence. In the event of a conflict between the text of this drawing and the references cited herein, the text of this drawing takes precedence. Nothing in this document, however, supersedes applicable laws and regulations unless a specific exemption has been obtained.

STANDARD MICROCIRCUIT DRAWING DEFENSE SUPPLY CENTER COLUMBUS COLUMBUS, OHIO 43218-3990	SIZE A		5962-89522
		REVISION LEVEL H	SHEET 5

3. REQUIREMENTS

3.1 Item requirements. The individual item performance requirements for device classes D, E, G, H, and K shall be in accordance with MIL-PRF-38534. Compliance with MIL-PRF-38534 may include the performance of all tests herein or as designated in the device manufacturer's Quality Management (QM) plan or as designated for the applicable device class. The manufacturer may eliminate, modify or optimize the tests and inspections herein, however the performance requirements as defined in MIL-PRF-38534 shall be met for the applicable device class. In addition, the modification in the QM plan shall not affect the form, fit, or function of the device for the applicable device class.

3.2 Design, construction, and physical dimensions. The design, construction, and physical dimensions shall be as specified in MIL-PRF-38534 and herein.

3.2.1 Case outline(s). The case outline(s) shall be in accordance with 1.2.4 herein and figure 1.

3.2.2 Terminal connections. The terminal connections shall be as specified on figure 2.

3.2.3 Timing waveforms. The timing waveforms shall be as specified on figures 3 and 5.

3.2.4 Transceiver zero crossing test setup. The transceiver zero crossing test setup shall be as specified on figure 4.

3.3 Electrical performance characteristics. Unless otherwise specified herein, the electrical performance characteristics are as specified in table I and shall apply over the full specified operating temperature range.

3.4 Electrical test requirements. The electrical test requirements shall be the subgroups specified in table II. The electrical tests for each subgroup are defined in table I.

3.5 Marking of device(s). Marking of device(s) shall be in accordance with MIL-PRF-38534. The device shall be marked with the PIN listed in 1.2 herein. In addition, the manufacturer's vendor similar PIN may also be marked.

3.6 Data. In addition to the general performance requirements of MIL-PRF-38534, the manufacturer of the device described herein shall maintain the electrical test data (variables format) from the initial quality conformance inspection group A lot sample, for each device type listed herein. Also, the data should include a summary of all parameters manually tested, and for those which, if any, are guaranteed. This data shall be maintained under document revision level control by the manufacturer and be made available to the preparing activity (DSCC-VA) upon request.

3.7 Certificate of compliance. A certificate of compliance shall be required from a manufacturer in order to supply to this drawing. The certificate of compliance (original copy) submitted to DSCC-VA shall affirm that the manufacturer's product meets the performance requirements of MIL-PRF-38534 and herein.

3.8 Certificate of conformance. A certificate of conformance as required in MIL-PRF-38534 shall be provided with each lot of microcircuits delivered to this drawing.

STANDARD MICROCIRCUIT DRAWING DEFENSE SUPPLY CENTER COLUMBUS COLUMBUS, OHIO 43218-3990	SIZE A		5962-89522
		REVISION LEVEL H	SHEET 6

TABLE I. Electrical performance characteristics.

Test	Symbol	Conditions <u>1/ 2/</u> -55°C ≤ T _C ≤ +125°C unless otherwise specified	Group A subgroups	Device type	Limits		Unit
					Min	Max	
RECEIVER							
Output low voltage	V _{OL}	I _{OL} = 4.0 mA	1, 2, 3	01,02,03, 04,05,08, 11,12		0.5	V
		I _{OL} = 8.0 mA		06,07,09, 10			
Output high voltage	V _{OH}	I _{OH} = -0.4 mA	1, 2, 3	01-10	2.4		V
				11,12	2.5		
Differential input level	V _I	<u>3/</u>	4,5,6	All		±8.0	Vp-p
Input common-mode voltage	V _{ICM}	<u>3/</u>	4,5,6	01,02,04, 08		±2.5	V
				03,06,07, 09,10,11, 12		±5.0	
				05		±10.0	
Differential input resistance	R _{IN}	1 MHz sine-wave <u>3/</u>	4,5,6	01,04,08	2.0		kΩ
				02,03,11, 12	10		
				06,07,09, 10	1.7		
				05	9.0		
Input capacitance	C _{IN}	1 MHz sine-wave <u>3/</u>	4,5,6	All		5.0	pf
Threshold voltage	V _{TH}	<u>4/</u>	4,5,6	All	0.60	1.2	V
Receiver delay	t _{DR}	From input zero crossing to DATA or $\overline{\text{DATA}}$, See figure 3	9, 10, 11	01-04, 06-12		500	ns
				05		450	
Zero crossing deviation	t _{DZ}	See figures 3 and 4 <u>3/ 8/</u>	9, 10, 11	11	496	504	ns

See footnotes at end of table.

STANDARD MICROCIRCUIT DRAWING DEFENSE SUPPLY CENTER COLUMBUS COLUMBUS, OHIO 43218-3990	SIZE A		5962-89522
		REVISION LEVEL H	SHEET 7

TABLE I. Electrical performance characteristics - Continued.

Test	Symbol	Conditions <u>1/ 2/</u> -55°C ≤ T _C ≤ +125°C unless otherwise specified	Group A subgroups	Device type	Limits		Unit
					Min	Max	
RECEIVER STROBE							
Input low voltage	V _{SIL}	<u>7/</u>	1,2,3	All		0.7	V
Input high voltage	V _{SIH}	<u>7/</u>	1,2,3	All	2.0		V
Input low current	I _{SIL}	V _{SIL} = 0.4 V	1,2,3	01-04, 05, 08, 11,12	-0.8		mA
				06,07,09, 10	-1.6		
Input high current	I _{SIH}	V _{SIH} = 2.7 V	1,2,3	All		40.0	μA
Strobe delay	t _{DS}	From strobe rising or falling edge to DATA or $\overline{\text{DATA}}$, See figure 3 <u>3/</u>	9, 10, 11	01-04,05, 08		78	ns
				06,07,09, 10		160	
				11,12		100	
TRANSMITTER							
Input low voltage	V _{IL}	<u>7/</u>	1,2,3	01,04		0.8	V
				02,03,05, 06-12		0.7	
Input high voltage	V _{IH}	<u>7/</u>	1,2,3	All	2.0		V
Input low current	I _{IL}	V _{IL} = 0.4 V	1,2,3	01,04	-3.2		mA
				02,03,08, 11,12	-0.4		
				05	-1.0		
				06,07,09, 10	-1.6		
See footnotes at end of table.							
STANDARD MICROCIRCUIT DRAWING DEFENSE SUPPLY CENTER COLUMBUS COLUMBUS, OHIO 43218-3990			SIZE A		5962-89522		
					REVISION LEVEL H		SHEET 8

TABLE I. Electrical performance characteristics - Continued.

Test	Symbol	Conditions <u>1/ 2/</u> -55°C ≤ T _C ≤ +125°C unless otherwise specified	Group A subgroups	Device type	Limits		Unit
					Min	Max	
TRANSMITTER - Continued							
Input high current	I _{IH}	V _{IH} = 2.7 V	1,2,3	01,04		80	μA
				02,03,06 07-12		40	
				05		100	
Differential out voltage	V _O	35Ω load <u>5/</u>	1,2,3	All	6.0	9.0	V _{P-P}
		140Ω load <u>3/ 5/</u>			24	36	
Differential out noise	V _{ON}	Inhibited	4,5,6	All		10.0	mV _{P-P}
Differential out resistance	R _{OUT}	Transmitter off <u>3/</u>	4,5,6	01-04, 06-10	10.0		kΩ
				05	5.0		
Differential out high Z	Z _{OUT}	Transmitter off <u>10/</u>	4,5,6	11,12	1.0		kΩ
Output capacitance	C _{OUT}	1 MHz sine-wave <u>3/</u>	4,5,6	01-04, 05, 08		15	pf
				06,07, 09, 10-12		20	
Differential offset voltage	V _{OS}	35Ω load <u>3/ 6/</u>	4,5,6	All		±90	mV pk
		140Ω load <u>3/ 6/</u>				±360	mV _{P-P}
Rise time	t _R	35Ω load, see figure 3	9, 10, 11	All	100	300	ns
Fall time	t _F						
Driver delay	t _{DT}	TX in to TX out, <u>3/</u> See figure 3	9, 10, 11	01-04, 06-10		450	ns
				05		150	
				11,12		250	

See footnotes at end of table.

STANDARD MICROCIRCUIT DRAWING DEFENSE SUPPLY CENTER COLUMBUS COLUMBUS, OHIO 43218-3990	SIZE A		5962-89522
		REVISION LEVEL H	SHEET 9

TABLE I. Electrical performance characteristics - Continued.

Test	Symbol	Conditions <u>1/ 2/</u> -55°C ≤ T _C ≤ +125°C unless otherwise specified	Group A subgroups	Device type	Limits		Unit
					Min	Max	
TRANSMITTER INHIBIT							
Input low voltage	V _{IIL}	<u>7/</u>	1,2,3	01,04		0.8	V
				02,03,05, 06-12		0.7	
Input high voltage	V _{IHH}	<u>7/</u>	1,2,3	All	2.0		V
Input low current	I _{IIL}	V _{IIL} = 0.4 V	1,2,3	01,04,06, 07,09,10	-1.6		mA
				02,03,08, 11,12	-0.4		
				05	-1.0		
Input high current	I _{IHH}	V _{IHH} = 2.4 V	1,2,3	01,04		80	μA
		V _{IHH} = 2.7 V		02,03,05, 08,11,12		40	
				06,07,09, 10		40	
Inhibit delay	t _{DI-H}	Inhibited output, <u>3/</u> See figure 3	9,10,11	01,02,03, 04,08,11, 12		450	ns
				06,07,09, 10		600	
				05		225	
	t _{DI-L}	Active output, <u>3/</u> See figure 3		01,02,03, 04,08,11, 12		250	
				06,07,09, 10		450	
				05		150	

See footnotes at end of table.

STANDARD MICROCIRCUIT DRAWING DEFENSE SUPPLY CENTER COLUMBUS COLUMBUS, OHIO 43218-3990	SIZE A		5962-89522
		REVISION LEVEL H	SHEET 10

TABLE I. Electrical performance characteristics - Continued.

Test	Symbol	Conditions <u>1/ 2/</u> -55°C ≤ T _C ≤ +125°C unless otherwise specified	Group A subgroups	Device type	Limits		Unit
					Min	Max	
POWER SUPPLY							
Supply current	I _{CC1}	Standby <u>9/</u>	1,2,3	01,04		49	mA
				02,06,07, 08,09,10		45	
				03		40	
				05		60	
				11,12		30	
	I _{CC2}	25% duty cycle <u>3/ 9/</u>	4,5,6	01,04,06, 07,09,10		220	mA
				02,08		167	
				11,12		195	
				03		190	
				05		180	
	I _{CC3}	50% duty cycle <u>3/ 9/</u>	4,5,6	01,04		380	mA
				02,08		350	
				11,12		345	
				06,07,09, 10		400	
				03		330	
05					305		

See footnotes at end of table.

STANDARD MICROCIRCUIT DRAWING DEFENSE SUPPLY CENTER COLUMBUS COLUMBUS, OHIO 43218-3990	SIZE A		5962-89522
		REVISION LEVEL H	SHEET 11

TABLE I. Electrical performance characteristics - Continued.

Test	Symbol	Conditions <u>1/ 2/</u> -55°C ≤ T _C ≤ +125°C unless otherwise specified	Group A subgroups	Device type	Limits		Unit
					Min	Max	
POWER SUPPLY - Continued							
Power supply	I _{CC4}	100% duty cycle <u>3/ 9/</u>	4,5,6	01,04		700	mA
				02,08		670	
				11,12		650	
				06,07,09, 10		800	
				03		600	
				05		550	

- 1/ V_{CC} = 5.0 V dc ±0.1 V dc, unless otherwise specified.
- 2/ All specifications and limits are for a single channel with no connections made to the other channel.
- 3/ Parameter shall be tested as part of device characterization and after design and process changes. Parameter shall be guaranteed to the limits specified in table I for all lots not specifically tested.
- 4/ Threshold determined by first missing word of a 33 word transmission to a 1553 CMOS Manchester encoder-decoder.
- 5/ Device type 02 is guaranteed to output 6.5 V_{p-p} across 35Ω load or 26 V_{p-p} across 140Ω load over the full case temperature range provided that the power supply voltage is no less than 5.0 V.
- 6/ Offset is measured 2.5 μs after mid-bit zero crossing of the last parity bit of a 660 μs transmission.
- 7/ These parameters are tested on a go-no-go basis in conjunction with other measured parameters and are not directly testable.
- 8/ Zero crossing deviations on channel A and B equal to or less than 4.0 ns from the ideal crossing point, measured with respect to the previous crossing point. The T2 parameter in figure 5 shall measure between 496 and 504 ns. Figure 4 shows the Device Under Test (DUT) setup. Figure 5 shows the measurement waveforms for the receiver timing. The zero crossing distortion measurements shall be made in accordance with MIL-HDBK-1553 for a transformer coupled stub. The rise and fall time of the transmitted message (measured at a data bit zero crossing with the prior zero crossing and the next zero crossing at 500 ns intervals from the measured zero crossing) measured at point "A" shall be 200 ±20 ns. The 2.1 volt peak to peak input voltage measurement shall be taken at point "A" as shown in figure 4. The V_{CC} decoupling used in the test setup is 4.7 μF, minimum.
- 9/ Typical power for device type 11 and 12 is measured with V_{BUS} = 7 Vp-p at the BUS across a 35Ω load with a 1:2.12 transformer.
- 10/ Power on or off, measured from 75 kHz to 1 MHz at point "A" of figure 4 and transformer self impedance of 3k Ω minimum.

STANDARD MICROCIRCUIT DRAWING DEFENSE SUPPLY CENTER COLUMBUS COLUMBUS, OHIO 43218-3990	SIZE A		5962-89522
		REVISION LEVEL H	SHEET 12

Case outline X

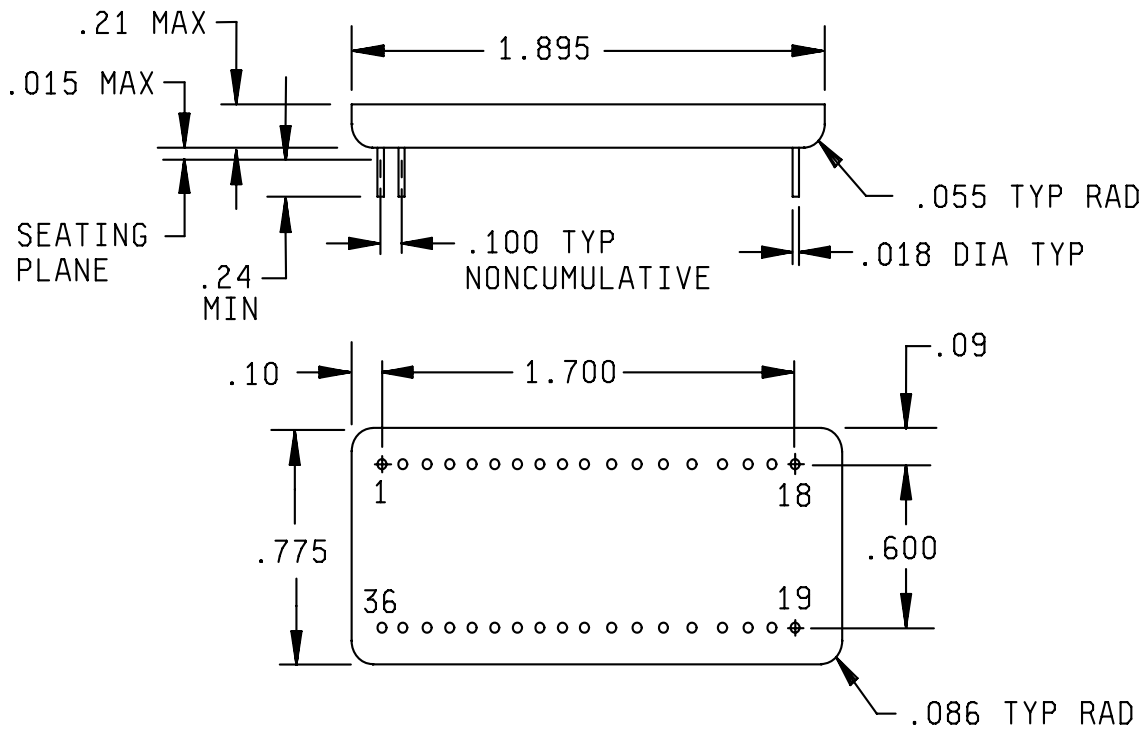

Inches	mm
.005	0.13
.015	0.38
.018	0.46
.055	1.40
.086	2.18
.090	2.28
.10	2.5
.21	5.3
.25	6.4
.600	15.24
.775	19.68
1.700	43.18
1.895	48.13

NOTES:

1. Dimensions are in inches.
2. Metric equivalents are for general information only.
3. Unless otherwise specified, tolerance is ± 0.005 (0.13 mm) for three place decimals and ± 0.01 (0.25 mm) for two place decimals.
4. Lead identification numbers are for reference only.
5. Lead spacing dimensions apply only at seating plane.

FIGURE 1. Case outline(s).

STANDARD MICROCIRCUIT DRAWING DEFENSE SUPPLY CENTER COLUMBUS COLUMBUS, OHIO 43218-3990	SIZE A		5962-89522
		REVISION LEVEL H	SHEET 13

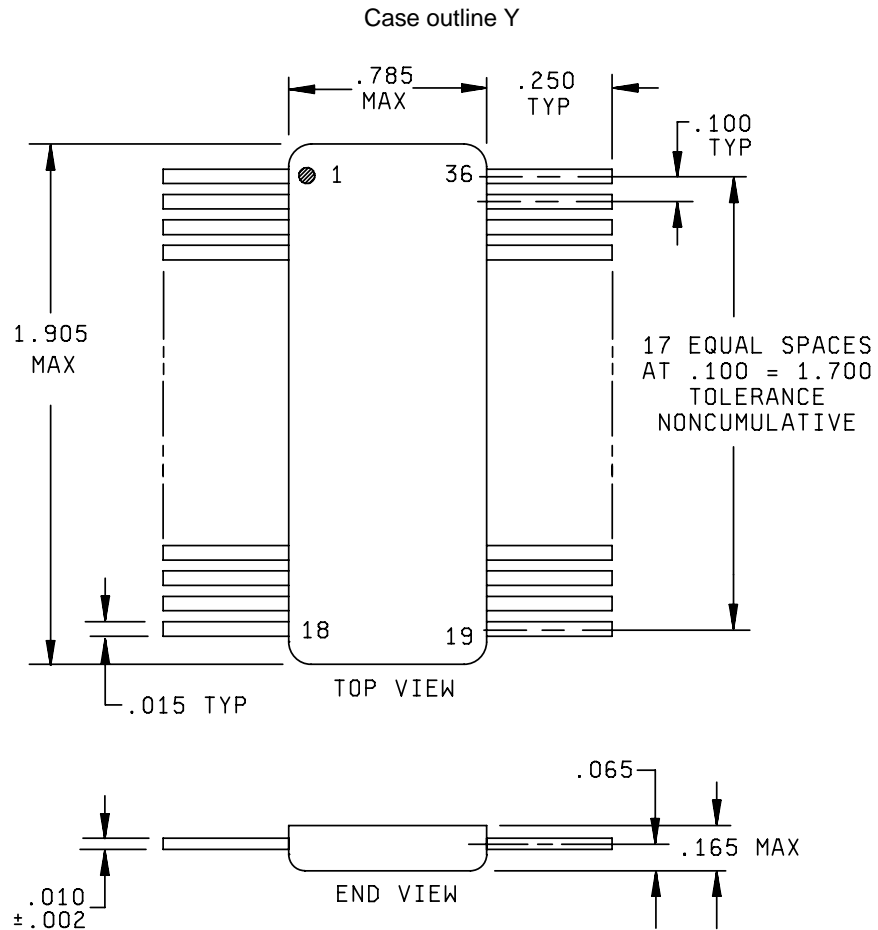

Inches	mm
.002	0.05
.010	0.25
.015	0.38
.065	1.65
.100	2.54
.165	4.19
.250	6.35
.785	19.94
1.700	43.18
1.905	48.39

NOTES:

1. Dimensions are in inches.
2. Metric equivalents are for general information only.
3. Unless otherwise specified, tolerance is $\pm .005$ (0.13 mm) for three place decimals and $\pm .01$ (0.25 mm) for two place decimals.
4. Lead identification numbers are for reference only.

FIGURE 1. Case outline(s) - Continued.

STANDARD MICROCIRCUIT DRAWING DEFENSE SUPPLY CENTER COLUMBUS COLUMBUS, OHIO 43218-3990	SIZE A		5962-89522
		REVISION LEVEL H	SHEET 14

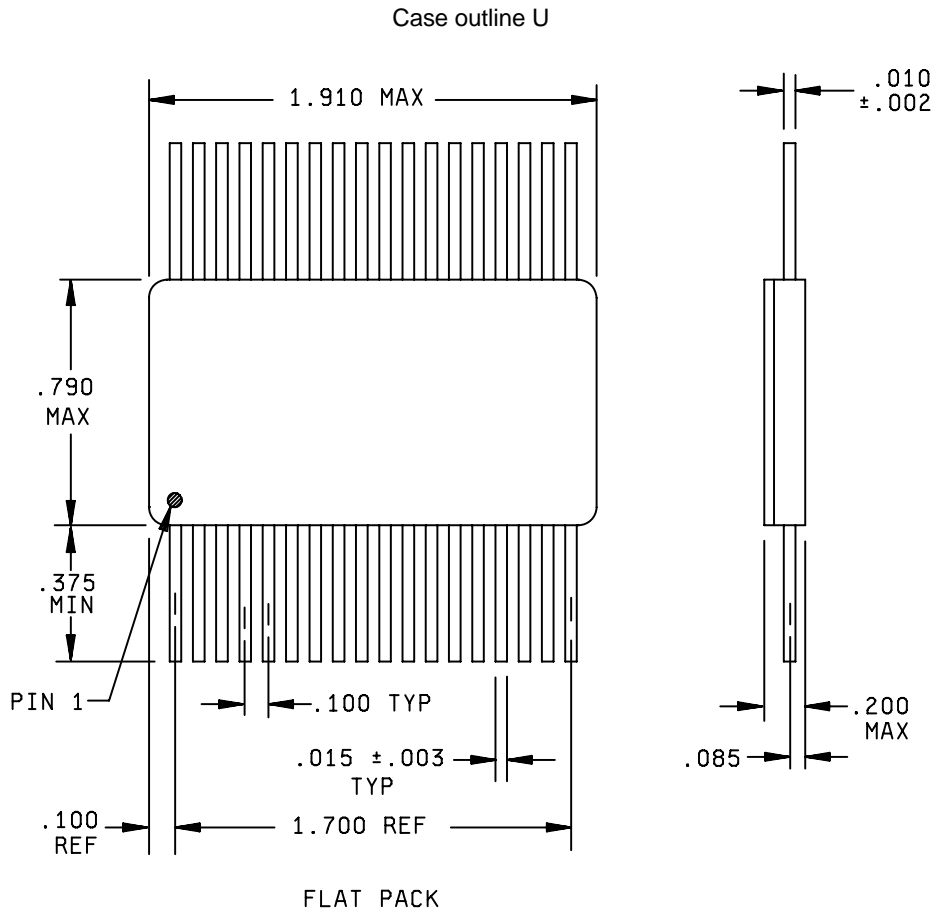

Inches	mm
.002	0.05
.003	0.13
.010	0.25
.015	0.38
.085	2.16
.100	2.54
.200	5.08
.375	9.53
.790	20.07
1.700	43.18
1.910	48.51

NOTES:

1. Dimensions are in inches.
2. Metric equivalents are for general information only.
3. Unless otherwise specified, tolerance is ± 0.005 (0.13 mm) for three place decimals and ± 0.01 (0.25 mm) for two place decimals.

FIGURE 1. Case outline(s) - Continued.

STANDARD MICROCIRCUIT DRAWING DEFENSE SUPPLY CENTER COLUMBUS COLUMBUS, OHIO 43218-3990	SIZE A		5962-89522
		REVISION LEVEL H	SHEET 15

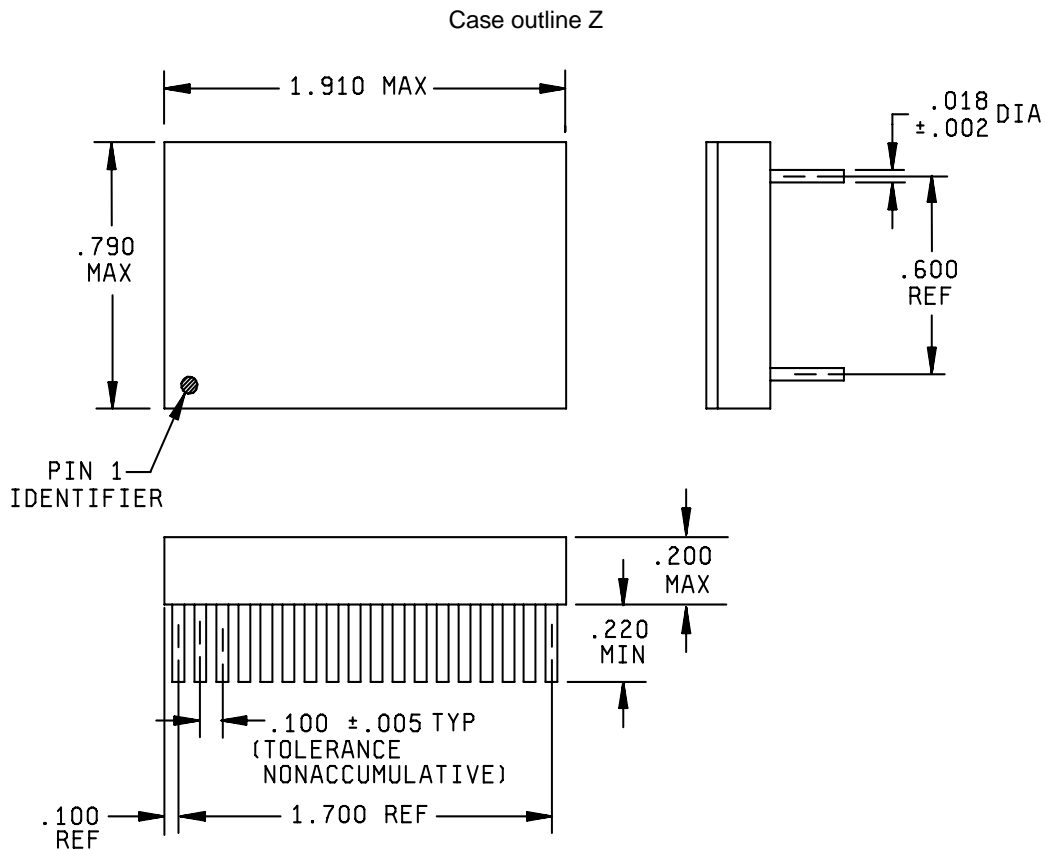

Inches	mm
.002	0.05
.005	0.13
.018	0.46
.100	2.54
.200	5.08
.220	5.59
.600	15.24
.775	19.68
.790	20.07
1.700	43.18
1.895	48.13
1.910	48.51

NOTES:

1. Dimensions are in inches.
2. Metric equivalents are for general information only.
3. Unless otherwise specified, tolerance is ±.005 (0.13 mm) for three place decimals and ±.01 (0.25 mm) for two place decimals.

FIGURE 1. Case outline(s) - Continued.

STANDARD MICROCIRCUIT DRAWING DEFENSE SUPPLY CENTER COLUMBUS COLUMBUS, OHIO 43218-3990	SIZE A		5962-89522
		REVISION LEVEL H	SHEET 16

Device type	All	
Case outlines	X, Y, Z, and U	
Terminal number	Terminal connection	
	Connection	Channel
1	TX DATA out	One
2	TX DATA out	One
3	GND	One
4	No connection	---
5	RX DATA out	One
6	Strobe	One
7	GND	One
8	RX DATA out	One
9	GND (case)	One
10	TX DATA out	Two
11	TX DATA out	Two
12	GND	Two
13	No connection	---
14	RX DATA out	Two
15	Strobe	Two
16	GND	Two
17	RX DATA out	Two
18	No connection	---
19	No connection	---
20	RX DATA in	Two
21	RX DATA in	Two
22	GND	Two
23	No connection	---
24	+5 V dc	Two
25	Inhibit	Two
26	TX DATA in	Two
27	TX DATA in	Two
28	No connection	---
29	RX DATA in	One
30	RX DATA in	One
31	GND	One
32	No connection	---
33	+5 V dc	One
34	Inhibit	One
35	TX DATA in	One
36	TX DATA in	One

NOTE: Terminal numbers 3 and 12 are no connections for device types 06, 07, 09, and 10.

FIGURE 2. Terminal connections.

STANDARD MICROCIRCUIT DRAWING DEFENSE SUPPLY CENTER COLUMBUS COLUMBUS, OHIO 43218-3990	SIZE A		5962-89522
		REVISION LEVEL H	SHEET 17

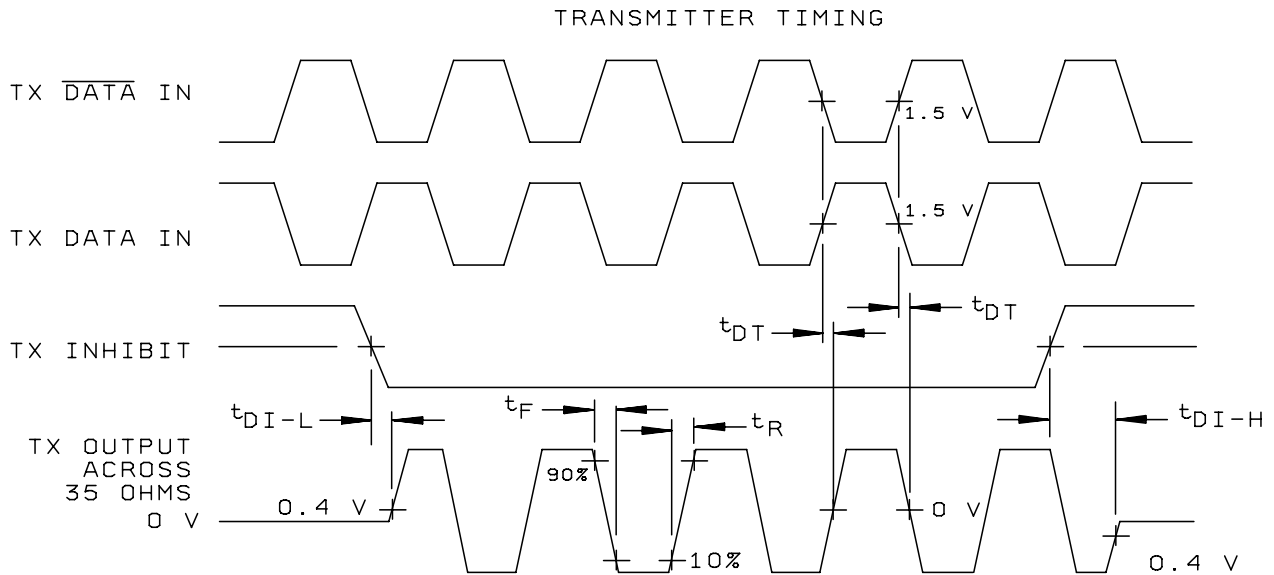
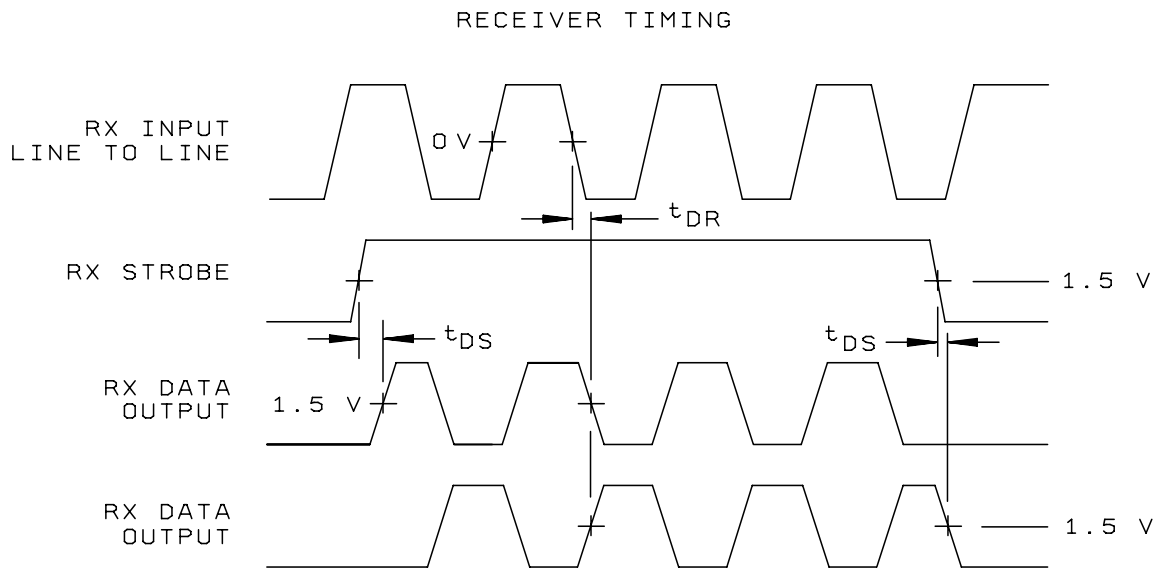

NOTE: Both inputs "TX DATA IN" and "TX DATA IN" must be in the same logic state during off times.

FIGURE 3. Timing waveforms.

STANDARD MICROCIRCUIT DRAWING DEFENSE SUPPLY CENTER COLUMBUS COLUMBUS, OHIO 43218-3990	SIZE A		5962-89522
		REVISION LEVEL H	SHEET 18

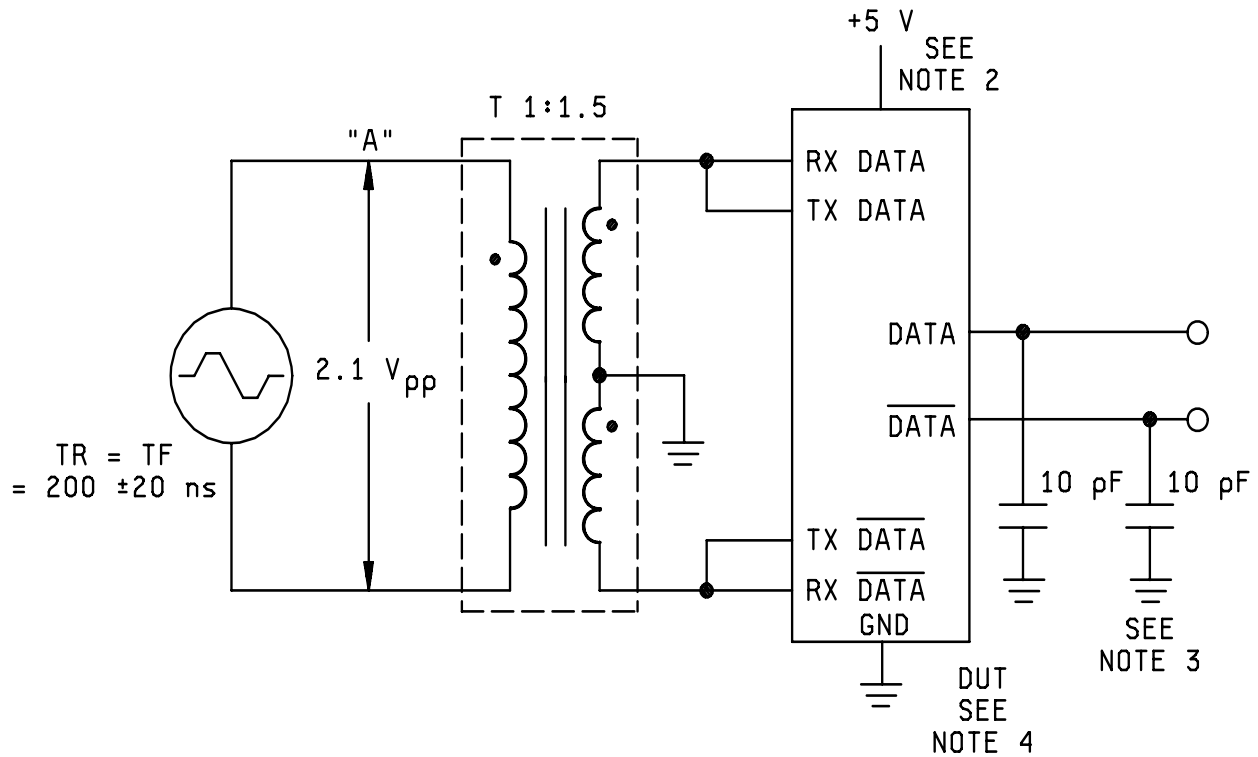

NOTES:

1. TR is the rise time of the transmitted message. TF is the fall time of the transmitted message.
2. The V_{CC} decoupling capacitor used in the test setup shall be 4.7 μF minimum.
3. Includes the strobe and jig capacitance.
4. One half of Device Under Test (DUT) shown.

FIGURE 4. Transceiver zero crossing test setup.

STANDARD MICROCIRCUIT DRAWING DEFENSE SUPPLY CENTER COLUMBUS COLUMBUS, OHIO 43218-3990	SIZE A		5962-89522
		REVISION LEVEL H	SHEET 19

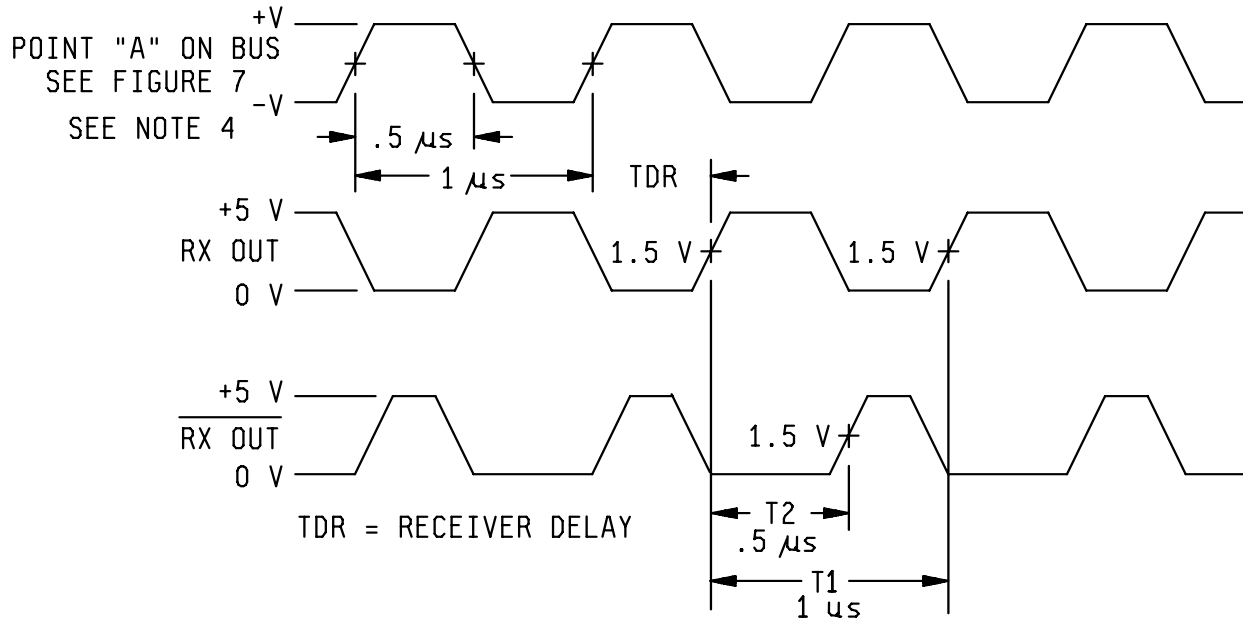

NOTES:

1. TDR is the zero crossing of the rising edge of the data bit on the bus (point "A" of figure 4) to the +1.5 V level on the rising edge of RX OUT.
2. T1 is the +1.5 V level from the rising edge of RX OUT to the same level on the next rising edge of RX OUT.
3. T2 is the +1.5 V level on the rising edge of RX OUT to the +1.5 V level up from ground on the rising edge of RX OUT.
4. Input waveform may be a 1 MHz sine or square wave.

FIGURE 5. Receiver timing waveforms.

STANDARD MICROCIRCUIT DRAWING DEFENSE SUPPLY CENTER COLUMBUS COLUMBUS, OHIO 43218-3990	SIZE A		5962-89522
		REVISION LEVEL H	SHEET 20

TABLE II. Electrical test requirements.

MIL-PRF-38534 test requirements	Subgroups (in accordance with MIL-PRF-38534, group A test table)
Interim electrical parameters	1
Final electrical parameters	1*, 2, 3, 4, 5, 6, 9, 10, 11
Group A test requirements	1, 2, 3, 4, 5, 6, 9, 10, 11
Group C end-point electrical parameters	1, 2, 3
End-point electrical parameters for Radiation Hardness Assurance (RHA) devices	Not applicable

* PDA applies to subgroup 1.

4. VERIFICATION

4.1 Sampling and inspection. Sampling and inspection procedures shall be in accordance with MIL-PRF-38534 or as modified in the device manufacturer's Quality Management (QM) plan. The modification in the QM plan shall not affect the form, fit, or function as described herein.

4.2 Screening. Screening shall be in accordance with MIL-PRF-38534. The following additional criteria shall apply:

- a. Burn-in test, method 1015 of MIL-STD-883.
 - (1) Test condition A, B, C, or D. The test circuit shall be maintained by the manufacturer under document revision level control and shall be made available to either DSCC-VA or the acquiring activity upon request. Also, the test circuit shall specify the inputs, outputs, biases, and power dissipation, as applicable, in accordance with the intent specified in method 1015 of MIL-STD-883.
 - (2) $T_C = +125^{\circ}\text{C}$, minimum.
- b. Interim and final electrical test parameters shall be as specified in table II herein, except interim electrical parameter tests prior to burn-in are optional at the discretion of the manufacturer.

4.3 Conformance and periodic inspections. Conformance inspection (CI) and periodic inspection (PI) shall be in accordance with MIL-PRF-38534 and as specified herein.

4.3.1 Group A inspection (CI). Group A inspection shall be in accordance with MIL-PRF-38534 and as follows:

- a. Tests shall be as specified in table II herein.
- b. Subgroups 7 and 8 shall be omitted.

4.3.2 Group B inspection (PI). Group B inspection shall be in accordance with MIL-PRF-38534.

STANDARD MICROCIRCUIT DRAWING DEFENSE SUPPLY CENTER COLUMBUS COLUMBUS, OHIO 43218-3990	SIZE A		5962-89522
		REVISION LEVEL H	SHEET 21

4.3.3 Group C inspection (PI). Group C inspection shall be in accordance with MIL-PRF-38534 and as follows:

- a. End-point electrical parameters shall be as specified in table II herein.
- b. Steady-state life test, method 1005 of MIL-STD-883.
 - (1) Test condition A, B, C, or D. The test circuit shall be maintained by the manufacturer under document revision level control and shall be made available to either DSCC-VA or the acquiring activity upon request. Also, the test circuit shall specify the inputs, outputs, biases, and power dissipation, as applicable, in accordance with the intent specified in method 1005 of MIL-STD-883.
 - (2) $T_C = +125^{\circ}\text{C}$, minimum.
 - (3) Test duration: 1,000 hours, except as permitted by method 1005 of MIL-STD-883.

4.3.4 Group D inspection (PI). Group D inspection shall be in accordance with MIL-PRF-38534.

4.3.5 Radiation Hardness Assurance (RHA) inspection. RHA inspection is not currently applicable to this drawing.

5. PACKAGING

5.1 Packaging requirements. The requirements for packaging shall be in accordance with MIL-PRF-38534.

6. NOTES

6.1 Intended use. Microcircuits conforming to this drawing are intended for use for Government microcircuit applications (original equipment), design applications, and logistics purposes.

6.2 Replaceability. Microcircuits covered by this drawing will replace the same generic device covered by a contractor-prepared specification or drawing.

6.3 Configuration control of SMD's. All proposed changes to existing SMD's will be coordinated as specified in MIL-PRF-38534.

6.4 Record of users. Military and industrial users shall inform Defense Supply Center Columbus (DSCC) when a system application requires configuration control and the applicable SMD. DSCC will maintain a record of users and this list will be used for coordination and distribution of changes to the drawings. Users of drawings covering microelectronic devices (FSC 5962) should contact DSCC-VA, telephone (614) 692-0544.

6.5 Comments. Comments on this drawing should be directed to DSCC-VA, Columbus, Ohio 43218-3990, or telephone (614) 692-1081.

6.6 Sources of supply. Sources of supply are listed in MIL-HDBK-103 and QML-38534. The vendors listed in MIL-HDBK-103 and QML-38534 have submitted a certificate of compliance (see 3.7 herein) to DSCC-VA and have agreed to this drawing.

STANDARD MICROCIRCUIT DRAWING DEFENSE SUPPLY CENTER COLUMBUS COLUMBUS, OHIO 43218-3990	SIZE A		5962-89522
		REVISION LEVEL H	SHEET 22

STANDARD MICROCIRCUIT DRAWING BULLETIN

DATE: 08-03-21

Approved sources of supply for SMD 5962-89522 are listed below for immediate acquisition information only and shall be added to MIL-HDBK-103 and QML-38534 during the next revisions. MIL-HDBK-103 and QML-38534 will be revised to include the addition or deletion of sources. The vendors listed below have agreed to this drawing and a certificate of compliance has been submitted to and accepted by DSCC-VA. This information bulletin is superseded by the next dated revisions of MIL-HDBK-103 and QML-38534. DSCC maintains an online database of all current sources of supply at <http://www.dscclia.mil/Programs/Smcr/>.

Standard microcircuit drawing PIN <u>1/</u>	Vendor CAGE number	Vendor similar PIN <u>2/</u>
5962-8952201XA 5962-8952201XC 5962-8952201YA 5962-8952201YC	57363 57363 57363 57363	NHI-1559/883 NHI-1559/883 NHI-1559FP/883 NHI-1559FP/883
5962-8952202XA 5962-8952202XA 5962-8952202XC 5962-8952202XC 5962-8952202YA 5962-8952202YA 5962-8952202YC 5962-8952202YC	57363 <u>3/</u> 57363 <u>3/</u> 57363 88379 57363 88379	NHI-1529/883 ARX-2453 NHI-1529/883 ARX-2453 NHI-1529FP/883 ARX-2453FP NHI-1529FP/883 ARX-2453FP
5962-8952203XA 5962-8952203XC 5962-8952203YA 5962-8952203YC	57363 57363 57363 57363	NHI-1529 NHI-1529 NHI-1529FP NHI-1529FP
5962-8952204XA 5962-8952204XC 5962-8952204YA 5962-8952204YC	57363 57363 57363 57363	NHI-1559/883 NHI-1559/883 NHI-1559FP/883 NHI-1559FP/883
5962-8952205UA 5962-8952205UC 5962-8952205ZA 5962-8952205ZC	<u>3/</u> <u>3/</u> <u>3/</u> <u>3/</u>	CT2521FP CT2521FP CT2521 CT2521
5962-8952206XA 5962-8952206XA 5962-8952206XC 5962-8952206XC 5962-8952206YA 5962-8952206YA 5962-8952206YC 5962-8952206YC 5962-8952206KYA 5962-8952206KYC	U4388 57363 U4388 57363 U4388 57363 U4388 57363 U4388 U4388	FC1553921 NHI-1529/883 FC1553921 NHI-1529/883 FC1553921FP NHI-1529FP/883 FC1553921FP NHI-1529FP/883 FC1553921FP FC1553921FP

STANDARD MICROCIRCUIT DRAWING BULLETIN - CONTINUED

DATE: 08-03-21

Standard microcircuit drawing PIN <u>1/</u>	Vendor CAGE number	Vendor similar PIN <u>2/</u>
5962-8952207XA 5962-8952207XA 5962-8952207XC 5962-8952207XC 5962-8952207YA 5962-8952207YA 5962-8952207YC 5962-8952207YC 5962-8952207KYA 5962-8952207KYC	U4388 57363 U4388 57363 U4388 57363 U4388 57363 U4388 U4388	FC1553923 NHI-1559/883 FC1553923 NHI-1559/883 FC1553923 NHI-1559FP/883 FC1553923 NHI-1559FP/883 FC1553923FP FC1553923FP
5962-8952208XA 5962-8952208XA 5962-8952208XC 5962-8952208XC 5962-8952208YA 5962-8952208YA 5962-8952208YC 5962-8952208YC	57363 <u>3/</u> 57363 <u>3/</u> 57363 88379 57363 88739	NHI-1529/883 ARX-3453 NHI-1529/883 ARX-3453 NHI-1529/883 ARX-3453FP NHI-1529/883 ARX-3453FP
5962-8952209XA 5962-8952209XA 5962-8952209XC 5962-8952209XC 5962-8952209YA 5962-8952209YA 5962-8952209YC 5962-8952209YC 5962-8952209KYA 5962-8952209KYC	U4388 57363 U4388 57363 U4388 57363 U4388 57363 U4388 U4388	FC1553922 NHI-1529/883 FC1553922 NHI-1529/883 FC1553922FP NHI-1529/883 FC1553922FP NHI-1529/883 FC1553922FP FC1553922FP
5962-8952210XA 5962-8952210XA 5962-8952210XC 5962-8952210XC 5962-8952210YA 5962-8952210YC	U4388 57363 U4388 57363 57363 57363	FC1553924 NHI-1559/883 FC1553924 NHI-1559/883 NHI-1559/883 NHI-1559/883
5962-8952211XA 5962-8952211XC 5962-8952211YA 5962-8952211YC	88379 88379 88379 88379	4453-001-6 4453-001-6 4453-201-6 4453-201-6
5962-8952212XA 5962-8952212XC 5962-8952212YA 5962-8952212YC	88379 88379 88379 88379	4453-001-3 4453-001-3 4453-201-3 4453-201-3

1/ The lead finish shown for each PIN representing a hermetic package is the most readily available from the manufacturer listed for that part. If the desired lead finish is not listed contact the Vendor to determine its availability.

2/ **Caution.** Do not use this number for item acquisition. Items acquired to this number may not satisfy the performance requirements of this drawing.

3/ No longer available from an approved source of supply.

STANDARD MICROCIRCUIT DRAWING BULLETIN - CONTINUED

DATE: 08-03-21

<u>Vendor CAGE number</u>	<u>Vendor name and address</u>
57363	National Hybrid Incorporated 2200 Smithtown Avenue Ronkonkoma, NY 11779-7359
88379	Aeroflex Circuit Technology Corporation 35 South Service Road Plainview, NY 11803-4193
U4388	C-MAC MicroTechnology South Denes Great Yarmouth, Norfolk England

The information contained herein is disseminated for convenience only and the Government assumes no liability whatsoever for any inaccuracies in the information bulletin.