

REVISIONS			
LTR	DESCRIPTION	DATE (YR-MO-DA)	APPROVED
A	Redrawn with changes. Added devices 05, 06, and 07 for cage code 32116. Made changes to table I and figures 1, 2, and 3.	94-04-08	K. A. Cottongim
B	Delete CAGE code 32116. Made changes to table I.	95-06-02	K. A. Cottongim
C	Inactivate device types 01, 05, and 07 for new design. Add device type 08.	98-06-05	K. A. Cottongim
D	Table I; for device type 08 change the max limit for the t_{DR} test from 400 ns to 450 ns. Table I; for device type 08 change the max limit for the t_{DI-H} test from 200 ns to 225 ns. Redrew entire document. -sld	01-05-18	Raymond Monnin
E	Correct paragraphs 4.2.a.2. and 4.3.3.b.2 and add T_A . Paragraph 1.3, correct power dissipation for device types 01, 06, and 08 from 2 W to 2.5 W. Figure 2, terminal connections, case outlines X and Y, correct note to add 08 after 07 (2 places).	05-02-22	Raymond Monnin
F	Table I; changed the maximum limit for I_{CC1-SB} , I_{CC1-25} , I_{CC1-50} , and $I_{CC1-100}$ from 25 mA to 60 mA for device type 02. Editorial changes throughout. -sld	07-05-07	Robert M. Heber

--	--	--	--	--	--	--	--	--	--	--	--	--	--	--	--	--	--	--	--

REV																					
SHEET																					
REV	F	F	F	F	F	F	F	F													
SHEET	15	16	17	18	19	20	21	22													
REV STATUS				REV			F	F	F	F	F	F	F	F	F	F	F	F	F		
OF SHEETS				SHEET			1	2	3	4	5	6	7	8	9	10	11	12	13	14	
PMIC N/A	PREPARED BY Donald R. Osborne						DEFENSE SUPPLY CENTER COLUMBUS COLUMBUS, OHIO 43218-3990 http://www.dscc.dla.mil														
STANDARD MICROCIRCUIT DRAWING THIS DRAWING IS AVAILABLE FOR USE BY ALL DEPARTMENTS AND AGENCIES OF THE DEPARTMENT OF DEFENSE AMSC N/A	CHECKED BY Robert M. Heber																				
	APPROVED BY William K. Heckman																				
	DRAWING APPROVAL DATE 90-11-26																				
	REVISION LEVEL F																				
						SIZE A	CAGE CODE 67268	5962-89447													
						SHEET 1 OF 22															

1. SCOPE

1.1 Scope. This drawing documents five product assurance classes as defined in paragraph 1.2.3 and MIL-PRF-38534. A choice of case outlines and lead finishes which are available and are reflected in the Part or Identifying Number (PIN). When available, a choice of radiation hardness assurance levels are reflected in the PIN.

1.2 PIN. The PIN shall be as shown in the following example:

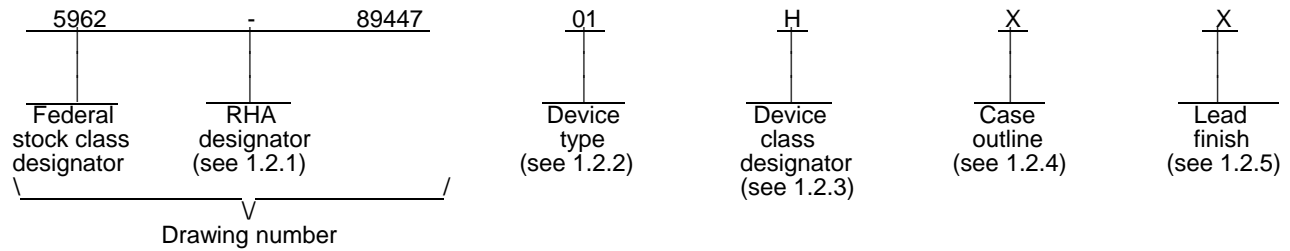

1.2.1 Radiation hardness assurance (RHA) designator. RHA marked devices shall meet the MIL-PRF-38534 specified RHA levels and shall be marked with the appropriate RHA designator. A dash (-) indicates a non-RHA device.

1.2.2 Device type(s). The device type(s) identify the circuit function as follows:

<u>Device types</u>	<u>Generic number</u>	<u>Circuit function</u>	<u>Coupling transformer turns ratio:</u>	
			<u>Direct</u>	<u>Transformer</u>
01 <u>1/</u>	ARX3416, ARX3436	Dual channel, driver-receiver receiver idle normally high	1.4:1	2:1
02	NHI-1501	"	1.4:1	2:1
03	FC1553622	"	1.4:1	2:1
04	BUS63135II, BUS63136II	"	1.4:1	2:1
05 <u>1/</u>	CT1487-DI	"	1.4:1	2:1
06 <u>2/</u>	ACT4487-DI-002	"	1.4:1	2:1
07 <u>1/</u>	CT1487-DFI	"	1.4:1	2:1
08 <u>1/</u>	ACT4436-DI, ACT4487-DI	"	1.4:1	2:1

1.2.3 Device class designator. This device class designator shall be a single letter identifying the product assurance level. All levels are defined by the requirements of MIL-PRF-38534 and require QML Certification as well as qualification (Class H, K, and E) or QML Listing (Class G and D). The product assurance levels are as follows:

<u>Device class</u>	<u>Device performance documentation</u>
K	Highest reliability class available. This level is intended for use in space applications.
H	Standard military quality class level. This level is intended for use in applications where non-space high reliability devices are required.
G	Reduced testing version of the standard military quality class. This level uses the Class H screening and In-Process Inspections with a possible limited temperature range, manufacturer specified incoming flow, and the manufacturer guarantees (but may not test) periodic and conformance inspections (Group A, B, C and D).
E	Designates devices which are based upon one of the other classes (K, H, or G) with exception(s) taken to the requirements of that class. These exception(s) must be specified in the device acquisition document; therefore the acquisition document should be reviewed to ensure that the exception(s) taken will not adversely affect system performance.
D	Manufacturer specified quality class. Quality level is defined by the manufacturers internal, QML certified flow. This product may have a limited temperature range.

1/ Device types 01, 05, and 07 are obsolete. Device type 08 replaces device types 01, 05, and 07.

2/ Device type 06, the generic number CT1892-500 is obsolete as of the date of revision B ,generic number 3416-511 is obsolete as of the date of revision C and generic number ARX3416-002 is obsolete as of the date of revision E.

STANDARD MICROCIRCUIT DRAWING DEFENSE SUPPLY CENTER COLUMBUS COLUMBUS, OHIO 43218-3990	SIZE A		5962-89447
		REVISION LEVEL F	SHEET 2

1.2.4 Case outline(s). The case outline(s) are as designated in MIL-STD-1835 and as follows:

<u>Outline letter</u>	<u>Descriptive designator</u>	<u>Terminals</u>	<u>Package style</u>
U	See figure 1	28	Dual-in-line
X	See figure 1	36	Dual-in-line
Y	See figure 1	36	Flat package
Z	See figure 1	36	Flat package

1.2.5 Lead finish. The lead finish shall be as specified in MIL-PRF-38534.

1.3 Absolute maximum ratings. ^{1/}

Supply voltage range:	
V_{CC} (devices 01, 02, 05, 06, 07, and 08)	-0.3 V dc to +18 V dc
V_{EE} (devices 01, 03, 04, 05, 06, 07, and 08).....	+0.3 V dc to -18 V dc
V_{CC1} (all devices)	-0.3 V dc to +7 V dc
Logic input voltage	-0.3 V dc to V_{CC1}
Receiver differential voltage.....	40 V_{P-P}
Receiver common mode voltage range	-10 V dc to +10 V dc
Driver peak output current	200 mA
Power dissipation (P_D) at $T_C = +125^\circ C$:	
(devices 01, 06, and 08)	2.5 W
(device 02).....	0.96 W
(device 03).....	1.65 W ^{2/}
(device 04).....	3 W ^{2/}
(devices 05 and 07)	3.8 W ^{2/}
Storage temperature range.....	-65°C to +150°C
Lead temperature (soldering, 10 seconds).....	+300°C
Junction temperature (T_J):	
(devices 01, 03, 06, and 08)	+167°C ^{3/ 4/}
(device 02).....	+145°C ^{3/ 5/}
(device 04).....	+160°C ^{3/ 6/}
(devices 05 and 07)	+150°C ^{3/}
Thermal resistance, junction-to-case (θ_{JC}):	
(devices 01, 06, and 08)	88°C/W
(device 02).....	8.8°C/W
(device 03).....	18°C/W
(device 04).....	7.0°C/W
(devices 05 and 07)	60°C/W

1.4 Recommended operating conditions.

Supply voltage range:	
V_{CC} (devices 01, 02, 05, 06, 07, and 08)	+14.25 V dc to +15.75 V dc
V_{EE} (devices 01, 03, 04, 05, 06, 07, and 08).....	-14.25 V dc to -15.75 V dc
V_{CC1} (all devices)	+4.5 V dc to +5.5 V dc
Logic input voltage	0 V dc to +5 V dc
Receiver differential voltage:	
(devices 01, 02, 05, 06, 07, and 08)	40 V_{P-P}
(devices 03 and 04)	30 V_{P-P}
Receiver common mode voltage range:	
(devices 01, 03, 04, 06, and 08)	-5 V dc to +5 V dc
(devices 02, 05, and 07)	-10 V dc to +10 V dc
Driver peak output current (all devices)	180 mA
Serial data rate	1.0 MHz maximum
Case operating temperature range (T_C).....	-55°C to +125°C

- ^{1/} Stresses above the absolute maximum rating may cause permanent damage to the device. Extended operation at the maximum levels may degrade the performance and affect reliability.
- ^{2/} One channel transmitting at 100 percent duty cycle and the second channel is at standby.
- ^{3/} Worst case operating junction temperature when case is held to +125°C.
- ^{4/} Maximum junction temperature rise above case temperature for the hottest die at 100% transmitting duty cycle shall be 42°C.
- ^{5/} Maximum junction temperature rise above case temperature for the hottest die at 100% transmitting duty cycle shall be 20°C.
- ^{6/} Maximum junction temperature rise above case temperature for the hottest die at 100% transmitting duty cycle shall be 21°C.

STANDARD MICROCIRCUIT DRAWING DEFENSE SUPPLY CENTER COLUMBUS COLUMBUS, OHIO 43218-3990	SIZE A		5962-89447
		REVISION LEVEL F	SHEET 3

2. APPLICABLE DOCUMENTS

2.1 Government specification, standards, and handbooks. The following specification, standards, and handbooks form a part of this drawing to the extent specified herein. Unless otherwise specified, the issues of these documents are those cited in the solicitation or contract.

DEPARTMENT OF DEFENSE SPECIFICATION

MIL-PRF-38534 - Hybrid Microcircuits, General Specification for.

DEPARTMENT OF DEFENSE STANDARDS

MIL-STD-883 - Test Method Standard Microcircuits.
 MIL-STD-1835 - Interface Standard for Electronic Component Case Outlines.

DEPARTMENT OF DEFENSE HANDBOOKS

MIL-HDBK-103 - List of Standard Microcircuit Drawings.
 MIL-HDBK-780 - Standard Microcircuit Drawings.
 MIL-HDBK-1553 - Multiplex Applications Handbook.

(Copies of these documents are available online at <http://assist.daps.dla.mil/quicksearch/> or <http://assist.daps.dla.mil> or from the Standardization Document Order Desk, 700 Robbins Avenue, Building 4D, Philadelphia, PA 19111-5094.)

2.2 Order of precedence. In the event of a conflict between the text of this drawing and the references cited herein, the text of this drawing takes precedence. Nothing in this document, however, supersedes applicable laws and regulations unless a specific exemption has been obtained.

3. REQUIREMENTS

3.1 Item requirements. The individual item performance requirements for device classes D, E, G, H, and K shall be in accordance with MIL-PRF-38534. Compliance with MIL-PRF-38534 shall include the performance of all tests herein or as designated in the device manufacturer's Quality Management (QM) plan or as designated for the applicable device class. The manufacturer may eliminate, modify or optimize the tests and inspections herein, however the performance requirements as defined in MIL-PRF-38534 shall be met for the applicable device class. In addition, the modification in the QM plan shall not affect the form, fit, or function of the device for the applicable device class.

3.2 Design, construction, and physical dimensions. The design, construction, and physical dimensions shall be as specified in MIL-PRF-38534 and herein.

3.2.1 Case outlines. The case outlines shall be in accordance with 1.2.4 herein and figure 1.

3.2.2 Terminal connections. The terminal connections shall be as specified on figure 2.

3.2.3 Timing waveforms. The timing waveforms shall be as specified on figure 3.

3.2.4 Typical transformer connection. The typical transformer connection shall be as specified on figure 4.

3.3 Electrical performance characteristics. Unless otherwise specified herein, the electrical performance characteristics are as specified in table I and shall apply over the full specified operating temperature range.

3.4 Electrical test requirements. The electrical test requirements shall be the subgroups specified in table II. The electrical tests for each subgroup are defined in table I.

3.5 Marking of device(s). Marking of device(s) shall be in accordance with MIL-PRF-38534. The device shall be marked with the PIN listed in 1.2 herein. In addition, the manufacturer's vendor similar PIN may also be marked.

STANDARD MICROCIRCUIT DRAWING DEFENSE SUPPLY CENTER COLUMBUS COLUMBUS, OHIO 43218-3990	SIZE A		5962-89447
		REVISION LEVEL F	SHEET 4

3.6 Data. In addition to the general performance requirements of MIL-PRF-38534, the manufacturer of the device described herein shall maintain the electrical test data (variables format) from the initial quality conformance inspection group A lot sample, for each device type listed herein. Also, the data should include a summary of all parameters manually tested, and for those which, if any, are guaranteed. This data shall be maintained under document revision level control by the manufacturer and be made available to the preparing activity (DSCC-VA) upon request.

3.7 Certificate of compliance. A certificate of compliance shall be required from a manufacturer in order to supply to this drawing. The certificate of compliance (original copy) submitted to DSCC-VA shall affirm that the manufacturer's product meets the performance requirements of MIL-PRF-38534 and herein.

3.8 Certificate of conformance. A certificate of conformance as required in MIL-PRF-38534 shall be provided with each lot of microcircuits delivered to this drawing.

4. VERIFICATION

4.1 Sampling and inspection. Sampling and inspection procedures shall be in accordance with MIL-PRF-38534 or as modified in the device manufacturer's Quality Management (QM) plan. The modification in the QM plan shall not affect the form, fit, or function as described herein.

4.2 Screening. Screening shall be in accordance with MIL-PRF-38534. The following additional criteria shall apply:

- a. Burn-in test, method 1015 of MIL-STD-883.
 - (1) Test condition A, B, C, or D. The test circuit shall be maintained by the manufacturer under document revision level control and shall be made available to either DSCC-VA or the acquiring activity upon request. Also, the test circuit shall specify the inputs, outputs, biases, and power dissipation, as applicable, in accordance with the intent specified in method 1015 of MIL-STD-883.
 - (2) T_A or T_C as specified in the approved manufacturer's QM plan.
- b. Interim and final electrical test parameters shall be as specified in table II herein, except interim electrical parameter tests prior to burn-in are optional at the discretion of the manufacturer.

STANDARD MICROCIRCUIT DRAWING DEFENSE SUPPLY CENTER COLUMBUS COLUMBUS, OHIO 43218-3990	SIZE A		5962-89447
		REVISION LEVEL F	SHEET 5

TABLE I. Electrical performance characteristics.

Test	Symbol	Conditions <u>1/</u> -55°C ≤ T _C ≤ +125°C unless otherwise specified	Group A subgroups	Device types	Limits		Unit
					Min	Max	
RECEIVER							
Input level	V _I	Differential input, pin 20 to pin 21, pin 29 to pin 30 <u>2/</u>	4,5,6	All		51	V _{P-P}
Input common mode voltage range	V _{ICM}	Independent of xfmr or in accordance with MIL- HDBK-1553 section 5.1.2.2	4,5,6	01,03,04, 06,08	-5	+5	V(pk)
				02,05,07	-10	+10	
Output low voltage	V _{OL}	I _{OL} = 4 mA	1,2,3	All		0.5	V
		I _{OL} = 16 mA		04		0.5	
Output high voltage	V _{OH}	I _{OH} = -0.4 mA	1,2,3	All	2.5		V
TRANSMITTER							
Input low voltage	V _{IL}		1,2,3	All		0.7	V
Input high voltage	V _{IH}		1,2,3	All	2		V
Input low current	I _{IL}	V _{IL} = 0.4 V	1,2,3	01,02,03, 06,08	-0.4		mA
				04,05,07	-1.0		
Input high current	I _{IH}	V _{IH} = 2.7 V	1,2,3	All		0.04	mA
Output voltage	V _O	Across 35Ω load	1,2,3	All	6	9	V _{P-P}
Output noise voltage	V _{ON}	Across 35Ω load	4,5,6	All		10	mV _{P-P}

See footnotes at end of table.

STANDARD MICROCIRCUIT DRAWING DEFENSE SUPPLY CENTER COLUMBUS COLUMBUS, OHIO 43218-3990	SIZE A		5962-89447
		REVISION LEVEL F	SHEET 6

TABLE I. Electrical performance characteristics - Continued.

Test	Symbol	Conditions 1/ -55°C ≤ T _C ≤ +125°C unless otherwise specified	Group A subgroups	Device types	Limits		Unit
					Min	Max	
RECEIVER STROBE							
Input low voltage	V _{SIL}		1,2,3	All		0.7	V
Input high voltage	V _{SIH}		1,2,3	All	2		V
Input low current	I _{SIL}	V _{SIL} = 0.4 V	1,2,3	01,06,08	-0.4		mA
				02,04	-0.72		
				03	-0.7		
				05,07	-1.0		
Input high current	I _{SIH}	V _{SIH} = 2.7 V	1,2,3	All		0.04	mA
TRANSMITTER INHIBIT							
Input low voltage	V _{IIL}		1,2,3	All		0.7	V
Input high voltage	V _{IIH}		1,2,3	All	2		
Input low current	I _{IIL}	V _{SIL} = 0.4 V	1,2,3	01,02,03, 06,08	-0.4		mA
				04	-0.72		
				05,07	-1.0		
Input high current	I _{IIH}	V _{SIH} = 2.7 V	1,2,3	01,02,03, 04,06,08		0.04	mA
				05,07		0.08	
See footnotes at end of table.							
STANDARD MICROCIRCUIT DRAWING DEFENSE SUPPLY CENTER COLUMBUS COLUMBUS, OHIO 43218-3990			SIZE A				5962-89447
					REVISION LEVEL F		SHEET 7

TABLE I. Electrical performance characteristics -Continued.

Test	Symbol	Conditions <u>1</u> / -55°C ≤ T _C ≤ +125°C unless otherwise specified	Group A subgroups	Device types	Limits		Unit
					Min	Max	
POWER SUPPLY							
Total Current	I _{CC} -SB	(standby mode)	1,2,3	01,08 02 05,06,07		1 25 22	mA
	I _{EE} -SB		1,2,3	01,03,08 04 05,06,07		16.5 30 35	
	I _{CC1} -SB		1,2,3	01,08 02 03 04,05,06, 07		30 60 35 45	
	I _{CC} -25	(25% duty cycle into 35Ω load)	4,5,6	01,08 02 05,06,07		55 69 80	
	I _{EE} -25		4,5,6	01,08 03 04 05,06,07		21 15 80 35	
	I _{CC1} -25		4,5,6	01,08 02 03,04,05, 06,07		30 60 45	
	I _{CC} -50	(50% duty cycle into 35Ω load)	4,5,6	01,08 02 05,06,07		110 118 130	
	I _{EE} -50		4,5,6	01,08 03,04 05,06,07		25 130 35	
	I _{CC1} -50		4,5,6	01,08 02 03,04,05, 06,07		30 60 45	

See footnotes at end of table.

STANDARD MICROCIRCUIT DRAWING DEFENSE SUPPLY CENTER COLUMBUS COLUMBUS, OHIO 43218-3990	SIZE A		5962-89447
		REVISION LEVEL F	SHEET 8

TABLE I. Electrical performance characteristics - Continued.

Test	Symbol	Conditions <u>1/</u> -55°C ≤ T _C ≤ +125°C unless otherwise specified	Group A subgroups	Device types	Limits		Unit
					Min	Max	
POWER SUPPLY - Continued.							
Total current	I _{CC} -100	(100% duty cycle into 35Ω load)	1,2,3	01,08 02 05,06,07		220 209 240	mA
	I _{EE} -100		1,2,3	01,08 03,04 05,06,07		30 255 35	
	I _{CC1} -100		1,2,3	01,08 02 03 04,05,06, 07		30 60 55 45	
RECEIVER							
Input resistance	R _{IN}	1 MHz sine wave	4,5,6	01,02,08 03,04 05,06,07	10 7 9		kΩ
Input capacitance	C _{IN}	1 MHz sine wave <u>2/</u> T _C = +25°C	4	All		5	pF
Threshold voltage	V _{TH}	<u>3/</u>	1,2,3	01,06,08	0.6	1.05	V _{P-P}
				02	0.6	1.10	
				03	0.6	1.15	
				04	0.56	1.0	
				05,07	0.8	1.1	
TRANSMITTER							
Output resistance (transmitter off)	R _{OUT}	1 MHz sine wave <u>2/</u>	4,5,6	01,02,03, 04,06,08	10		kΩ
				05,07	8		
See footnotes at end of table.							
STANDARD MICROCIRCUIT DRAWING DEFENSE SUPPLY CENTER COLUMBUS COLUMBUS, OHIO 43218-3990			SIZE A		5962-89447		
				REVISION LEVEL F	SHEET 9		

TABLE I. Electrical performance characteristics - Continued.

Test	Symbol	Conditions <u>1/</u> -55°C ≤ T _C ≤ +125°C unless otherwise specified	Group A subgroups	Device types	Limits		Unit
					Min	Max	
TRANSMITTER - Continued.							
Output capacitance (transmitter off)	C _{OUT}	1 MHz sine wave <u>2/</u> T _C = +25°C	4	All		5	pF
Output offset voltage	V _{OS}	<u>2/ 4/</u>	4,5,6	All		±90	mV(pk)
Peak amplitude variation	A _V	<u>5/</u>	4,5,6	All		±15	%
Zero cross stability	t _{S1}	Across 35Ω <u>2/</u> (See figure 3)	9,10,11	06	1975	2025	ns
	t _{S2}				475	525	
	t _{S3}				975	1025	
	t _{S4}				1475	1525	
RECEIVER							
Delay time, input to output	t _{DR}	Delay time from <u>2/</u> differential input zero _____ crossing to DATA or DATA (See figure 3)	9,10,11	01,02,03, 04,06		400	ns
				05,07		350	
				08		450	
Strobe delay	t _{DS}	Delay time from strobe <u>2/</u> rising or falling edge to DATA or DATA (See figure 3)	9,10,11	01,03,05, 06,07,08		250	
				02,04		200	
TRANSMITTER							
Rise time	t _R	Output load = 35Ω (See figure 3)	9,10,11	01,02,03, 04,05,07, 08	100	300	ns
				06	100	200	
See footnotes at end of table.							
STANDARD MICROCIRCUIT DRAWING DEFENSE SUPPLY CENTER COLUMBUS COLUMBUS, OHIO 43218-3990			SIZE A		5962-89447		
					REVISION LEVEL F		SHEET 10

TABLE I. Electrical performance characteristics - Continued.

Test	Symbol	Conditions <u>1/</u> -55°C ≤ T _C ≤ +125°C unless otherwise specified	Group A subgroups	Device types	Limits		Unit
					Min	Max	
TRANSMITTER - Continued.							
Fall time	t _F	(See figure 3)	9,10,11	01,02,03, 04,05,07, 08	100	300	ns
				06	100	200	
Delay time inhibiting	t _{DT}	(See figure 3) <u>2/</u>	9,10,11	01,03,06, 08		350	
				02,04		250	
				05,07		200	
Inhibit delay inhibiting	t _{DI-H}	(See figure 3) <u>2/</u>	9,10,11	01,02,06		200	
				03,04		450	
				05,07,08		225	
Inhibit delay active	t _{DI-L}	(See figure 3) <u>2/</u>	9,10,11	01,02,06, 08		200	
				03,04		450	
				05,07		150	

- 1/ V_{CC} = 15 V, V_{EE} = -15 V, and V_{CC1} = +5 V. All specifications and limits are for a single channel with no connections made to the other channel.
- 2/ This parameter is tested initially and after any design change which might affect this parameter.
- 3/ Threshold is measured in direct coupled mode including the transformer. Threshold is the maximum level on the BUS at which there are no pulses on either receiver output. Divide by 1.4 to obtain threshold in transformer coupled mode.
- 4/ Measured across 35Ω load, 2.5 μs after parity bit mid-bit zero crossing of 660 μs message.
- 5/ Measured across 35Ω load, variation of average peak amplitude.

STANDARD MICROCIRCUIT DRAWING DEFENSE SUPPLY CENTER COLUMBUS COLUMBUS, OHIO 43218-3990	SIZE A		5962-89447
		REVISION LEVEL F	SHEET 11

Case outline U.

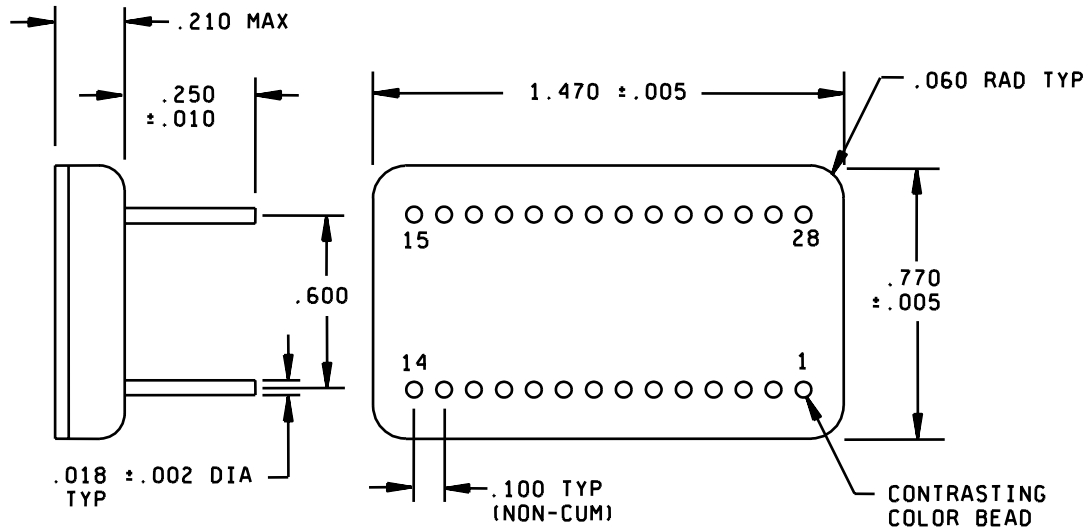

Inches	mm
.002	0.05
.005	0.13
.010	0.25
.018	0.46
.060	1.52
.100	2.54
.210	5.33
.250	6.35
.600	15.24
.770	19.56
1.470	37.34

NOTES:

1. Dimensions are in inches.
2. Metric equivalents are given for general information only.
3. Lead identification numbers are for reference only.
4. Lead spacing dimensions apply only at seating plane.

FIGURE 1. Case outline(s).

STANDARD MICROCIRCUIT DRAWING DEFENSE SUPPLY CENTER COLUMBUS COLUMBUS, OHIO 43218-3990	SIZE A		5962-89447
		REVISION LEVEL F	SHEET 12

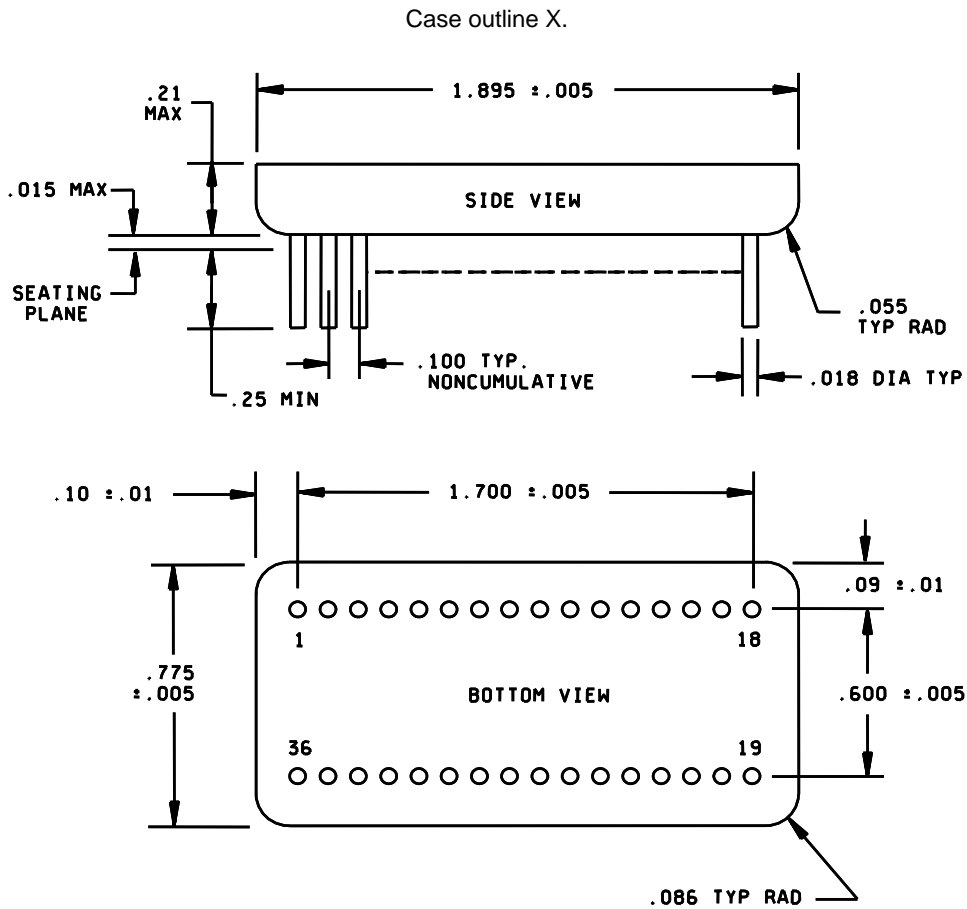

Inches	mm
.005	0.13
.01	0.3
.015	0.38
.018	0.46
.055	1.40
.086	2.18
.09	2.3
.10	2.5
.100	2.54
.600	15.24
.775	19.68
1.700	43.18
1.895	48.13

NOTES:

1. Dimensions are in inches.
2. Metric equivalents are given for general information only.
3. Lead identification numbers are for reference only.
4. Lead spacing dimensions apply only at seating plane.

FIGURE 1. Case outline(s) - Continued.

STANDARD MICROCIRCUIT DRAWING DEFENSE SUPPLY CENTER COLUMBUS COLUMBUS, OHIO 43218-3990	SIZE A		5962-89447
		REVISION LEVEL F	SHEET 13

Case outline Y.

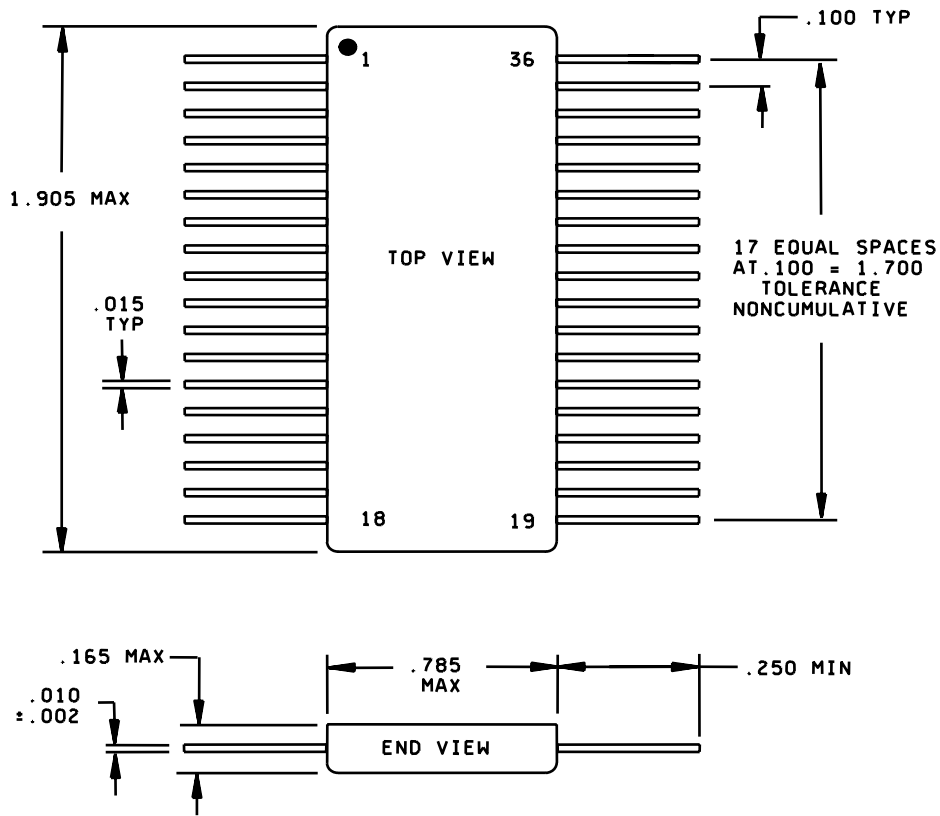

Inches	mm
.002	0.05
.010	0.25
.015	0.38
.100	2.54
.165	4.19
.250	6.35
.785	19.94
1.700	43.18
1.905	48.39

NOTES:

1. Dimensions are in inches.
2. Metric equivalents are given for general information only.
3. Lead identification numbers are for reference only.
4. Lead spacing dimensions apply only at seating plane.

FIGURE 1. Case outline(s) - Continued.

STANDARD MICROCIRCUIT DRAWING DEFENSE SUPPLY CENTER COLUMBUS COLUMBUS, OHIO 43218-3990	SIZE A		5962-89447
		REVISION LEVEL F	SHEET 14

Case outline Z.

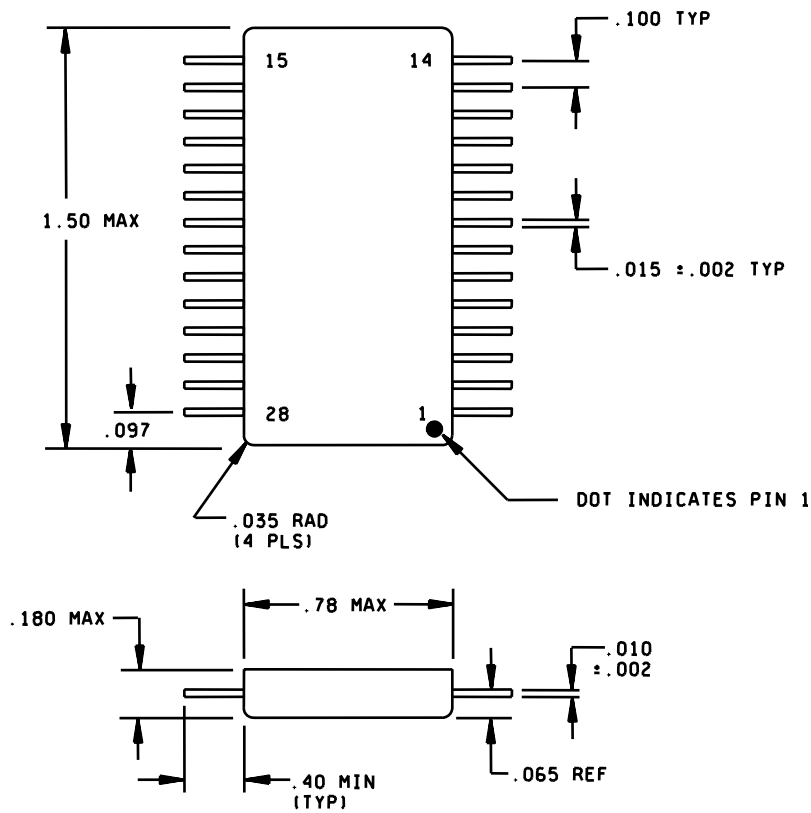

Inches	mm
.002	0.05
.003	0.08
.010	0.25
.015	0.38
.035	0.89
.065	1.65
.097	2.46
.100	2.54
.180	4.51
.40	10.16
.78	19.81
1.50	38.10

NOTES:

1. Dimensions are in inches.
2. Metric equivalents are given for general information only.
3. Lead identification numbers are for reference only.
4. Lead spacing dimensions apply only at seating plane.

FIGURE 1. Case outline(s) - Continued.

STANDARD MICROCIRCUIT DRAWING DEFENSE SUPPLY CENTER COLUMBUS COLUMBUS, OHIO 43218-3990	SIZE A		5962-89447
		REVISION LEVEL F	SHEET 15

Case outlines X and Y.

Pin	Function	Channel
1	TX <u>data</u> out	One
2	TX data out	One
3	GND or NC	One
4	NC	
5	RX data out	One
6	Strobe	One
7	<u>GND</u>	One
8	RX data out	One
9	GND or Case	One
10	TX <u>data</u> out	Two
11	TX data out	Two
12	GND or NC	Two
13	NC	
14	RX data out	Two
15	Strobe	Two
16	<u>GND</u>	Two
17	RX data out	Two
18	NC	
19	V _{CC} or NC	Two
20	RX <u>data</u> in	Two
21	RX data in	Two
22	GND	Two
23	V _{EE} or NC	Two
24	V _{CC1}	Two
25	Inhibit	Two
26	TX <u>data</u> in	Two
27	TX data in	Two
28	V _{CC} or NC	One
29	RX <u>data</u> in	One
30	RX data in	One
31	GND or NC	One
32	V _{EE} or NC	One
33	V _{CC1}	One
34	Inhibit	One
35	TX <u>data</u> in	One
36	TX data in	One

NOTE: GND pins should all be connected externally. For case outlines X and Y only, pins 19 and 28 are V_{CC} for device types 01, 02, 05, 06, 07, and 08 and no connects (NC's) for device types 03 and 04. Also for case outlines X and Y only, pins 23 and 32 are V_{EE} for device types 01, 03, 04, 05, 06, 07, and 08 and no connects (NC's) for device type 02.

FIGURE 2. Terminal connections.

STANDARD MICROCIRCUIT DRAWING DEFENSE SUPPLY CENTER COLUMBUS COLUMBUS, OHIO 43218-3990	SIZE A		5962-89447
		REVISION LEVEL F	SHEET 16

Case outlines U and Z.
(Device types 01 and 08).

Pin	Function	Channel
1	TX data out/RX <u>data</u> in	One
2	TX data out/RX data in	One
3	GND	One
4	RX <u>strobe</u>	One
5	RX data out	One
6	RX data out	One
7	Case	
8	TX data out/RX <u>data</u> in	Two
9	TX data out/RX data in	Two
10	GND	Two
11	RX <u>strobe</u>	Two
12	RX data out	Two
13	RX data out	Two
14	No connect	
15	GND	Two
16	V _{EE}	Two
17	V _{CC1}	Two
18	TX <u>inhibit</u>	Two
19	TX data in	Two
20	TX data in	Two
21	V _{CC}	Two
22	GND	One
23	V _{EE}	One
24	V _{CC1}	One
25	<u>Inhibit</u>	One
26	TX data in	One
27	TX data in	One
28	V _{CC}	One

NOTE: GND pins should all be connected externally.

FIGURE 2. Terminal connections - Continued.

STANDARD MICROCIRCUIT DRAWING DEFENSE SUPPLY CENTER COLUMBUS COLUMBUS, OHIO 43218-3990	SIZE A		5962-89447
		REVISION LEVEL F	SHEET 17

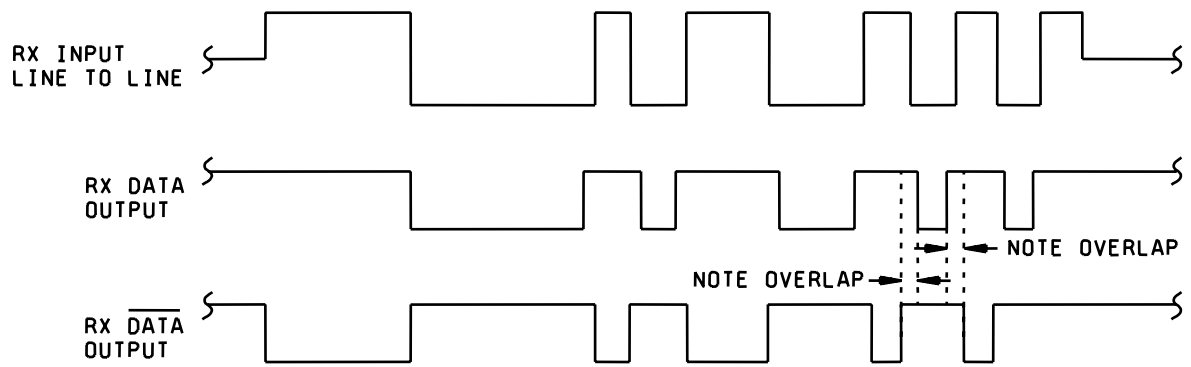

RECEIVER TIMING

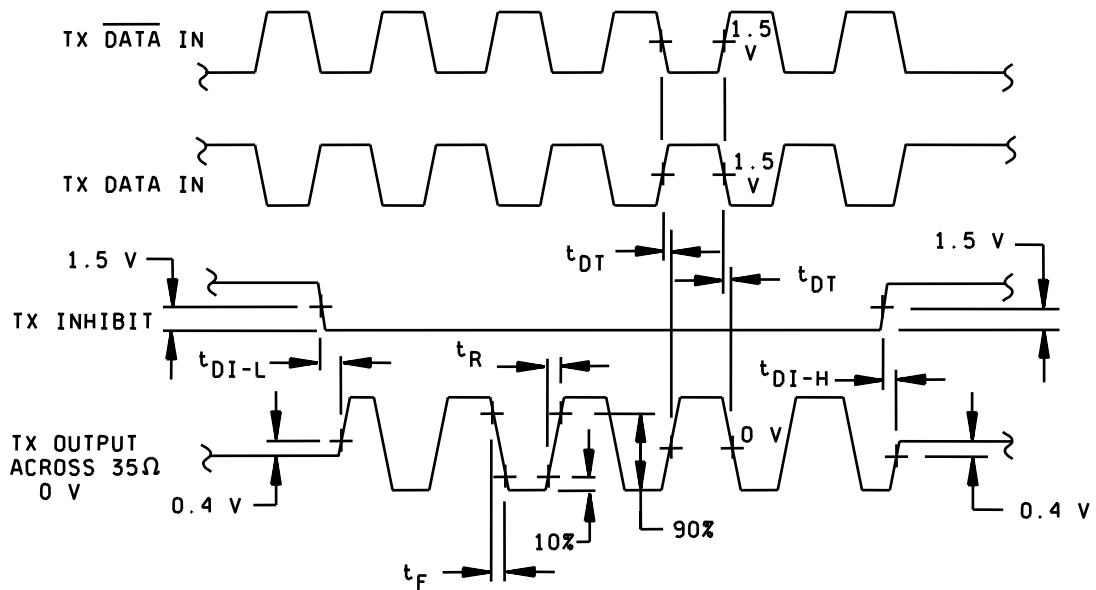

TRANSMITTER TIMING

FIGURE 3. Timing waveforms.

STANDARD MICROCIRCUIT DRAWING DEFENSE SUPPLY CENTER COLUMBUS COLUMBUS, OHIO 43218-3990	SIZE A		5962-89447
		REVISION LEVEL F	SHEET 18

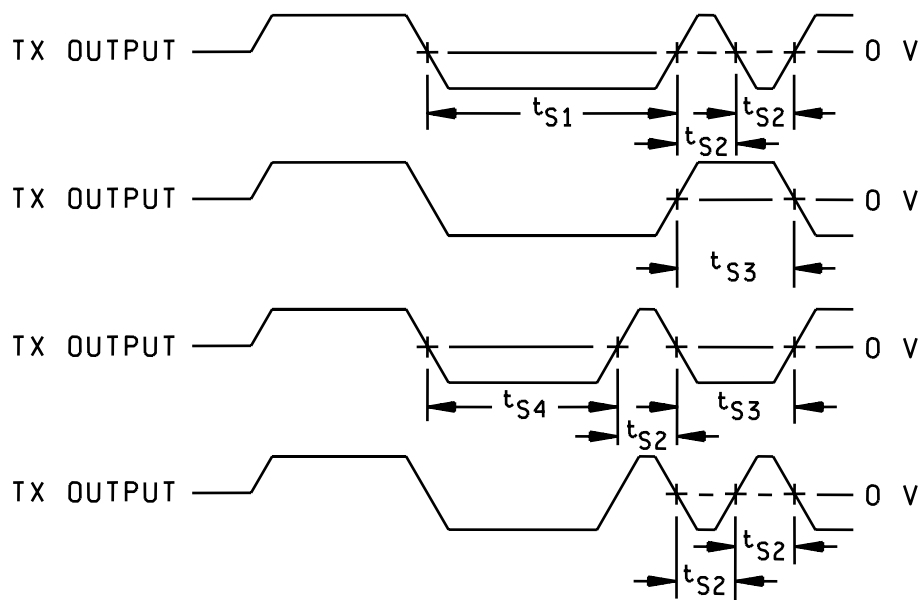

TRANSMISSION ZERO CROSS STABILITY

NOTE: Abbreviated waveform. Above relationships apply during entire transmission.

FIGURE 3. Timing waveforms - Continued.

STANDARD MICROCIRCUIT DRAWING DEFENSE SUPPLY CENTER COLUMBUS COLUMBUS, OHIO 43218-3990	SIZE A		5962-89447
		REVISION LEVEL F	SHEET 19

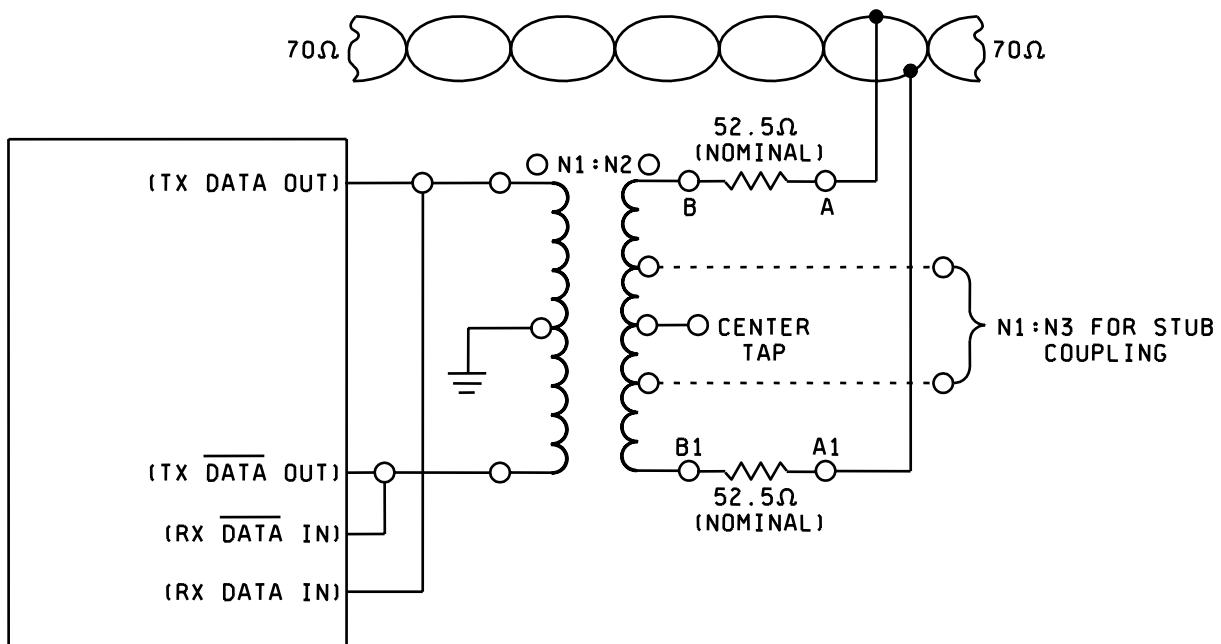

NOTES:

1. Device types 01, 02, 04, 05, 06, 07, and 08:
 $N1:N2 = 1.4:1$
 $N1:N3 = 2:1$
2. Device type 03:
 $N1:N2 = 2:1$
 $N1:N3 = 2:1$

FIGURE 4. Typical transformer connection.

STANDARD MICROCIRCUIT DRAWING DEFENSE SUPPLY CENTER COLUMBUS COLUMBUS, OHIO 43218-3990	SIZE A		5962-89447
		REVISION LEVEL F	SHEET 20

TABLE II. Electrical test requirements.

MIL-PRF-38534 test requirements	Subgroups (in accordance with MIL-PRF-38534, group A test table)
Interim electrical parameters	----
Final electrical parameters	1*,2,3,4,5,6,9,10,11
Group A test requirements	1,2,3,4,5,6,9,10,11
Group C end-point electrical parameters	1,2,3
End-point electrical parameters for Radiation Hardness Assurance (RHA) devices	Not applicable

* PDA applies to subgroup 1.

4.3 Conformance and periodic inspections. Conformance inspection (CI) and periodic inspection (PI) shall be in accordance with MIL-PRF-38534 and as specified herein.

4.3.1 Group A inspection (CI). Group A inspection shall be in accordance with MIL-PRF-38534 and as follows:

- a. Tests shall be as specified in table II herein.
- b. Subgroups 7 and 8 shall be omitted.

4.3.2 Group B inspection (PI). Group B inspection shall be in accordance with MIL-PRF-38534.

4.3.3 Group C inspection (PI). Group C inspection shall be in accordance with MIL-PRF-38534 and as follows:

- a. End-point electrical parameters shall be as specified in table II herein.
- b. Steady-state life test, method 1005 of MIL-STD-883.
 - (1) Test condition A, B, C, or D. The test circuit shall be maintained by the manufacturer under document revision level control and shall be made available to either DSCC-VA or the acquiring activity upon request. Also, the test circuit shall specify the inputs, outputs, biases, and power dissipation, as applicable, in accordance with the intent specified in method 1005 of MIL-STD-883.
 - (2) T_A or T_C as specified in the approved manufacturer's QM plan.
 - (3) Test duration: 1,000 hours, except as permitted by method 1005 of MIL-STD-883.

4.3.4 Group D inspection (PI). Group D inspection shall be in accordance with MIL-PRF-38534.

4.3.5 Radiation Hardness Assurance (RHA) inspection. RHA inspection is not currently applicable to this drawing.

STANDARD MICROCIRCUIT DRAWING DEFENSE SUPPLY CENTER COLUMBUS COLUMBUS, OHIO 43218-3990	SIZE A		5962-89447
		REVISION LEVEL F	SHEET 21

5. PACKAGING

5.1 Packaging requirements. The requirements for packaging shall be in accordance with MIL-PRF-38534.

6. NOTES

6.1 Intended use. Microcircuits conforming to this drawing are intended for use for Government microcircuit applications (original equipment), design applications, and logistics purposes.

6.2 Replaceability. Microcircuits covered by this drawing will replace the same generic device covered by a contractor-prepared specification or drawing.

6.3 Configuration control of SMD's. All proposed changes to existing SMD's will be coordinated as specified in MIL-PRF-38534.

6.4 Record of users. Military and industrial users shall inform Defense Supply Center Columbus (DSCC) when a system application requires configuration control and the applicable SMD. DSCC will maintain a record of users and this list will be used for coordination and distribution of changes to the drawings. Users of drawings covering microelectronic devices (FSC 5962) should contact DSCC-VA, telephone (614) 692-0544.

6.5 Comments. Comments on this drawing should be directed to DSCC-VA, Columbus, Ohio 43218-3990, or telephone (614) 692-1081.

6.6 Sources of supply. Sources of supply are listed in MIL-HDBK-103 and QML-38534. The vendors listed in MIL-HDBK-103 and QML-38534 have submitted a certificate of compliance (see 3.7 herein) to DSCC-VA and have agreed to this drawing.

STANDARD MICROCIRCUIT DRAWING DEFENSE SUPPLY CENTER COLUMBUS COLUMBUS, OHIO 43218-3990	SIZE A		5962-89447
		REVISION LEVEL F	SHEET 22

STANDARD MICROCIRCUIT DRAWING BULLETIN

DATE: 07-05-07

Approved sources of supply for SMD 5962-89447 are listed below for immediate acquisition information only and shall be added to MIL-HDBK-103 and QML-38534 during the next revisions. MIL-HDBK-103 and QML-38534 will be revised to include the addition or deletion of sources. The vendors listed below have agreed to this drawing and a certificate of compliance has been submitted to and accepted by DSCC-VA. This information bulletin is superseded by the next dated revisions of MIL-HDBK-103 and QML-38534. DSCC maintains an online database of all current sources of supply at <http://www.dscclia.mil/Programs/Smcr/>.

Standard microcircuit drawing PIN <u>1/</u>	Vendor CAGE number	Vendor similar PIN <u>2/</u>
5962-8944701HUX 5962-8944701HXX 5962-8944701HYX 5962-8944701HZX	<u>3/</u> <u>3/</u> <u>3/</u> <u>3/</u>	ARX3436-502 ARX3416-001-3 ARX3416FP-001-3 ARX3436FP-502
5962-8944702HXA 5962-8944702HXC 5962-8944702HYA 5962-8944702HYC	57363 57363 57363 57363	NHI-1501/883 NHI-1501/883 NHI-1501FP/883 NHI-1501FP/883
5962-8944703HXA 5962-8944703HXC 5962-8944703HYA 5962-8944703HYC	U4388 U4388 U4388 U4388	FC1553622 FC1553622 FC1553622FP FC1553622FP
5962-8944704HXC 5962-8944704HYC	19645 19645	BUS63135II BUS63136II
5962-8944705HXX	<u>3/</u>	CT1487-DI
5962-8944706HXA 5962-8944706HXC	88379 88379	ACT4487-DI-002-2 ACT4487-DI-002-1
5962-8944707HYX	<u>3/</u>	CT1487-DFI

- 1/ The lead finish shown for each PIN representing a hermetic package is the most readily available from the manufacturer listed for that part. If the desired lead finish is not listed contact the Vendor to determine its availability.
- 2/ Caution. Do not use this number for item acquisition. Items acquired to this number may not satisfy the performance requirements of this drawing.
- 3/ Not available from an approved source. Device type 08 replaces device types 01, 05, and 07.

STANDARD MICROCIRCUIT DRAWING BULLETIN - Continued.

DATE: 07-05-07

Standard microcircuit drawing PIN <u>1/</u>	Vendor CAGE number	Vendor similar PIN <u>2/</u>
5962-8944708HUA	88379	ACT4436-DI
5962-8944708HUC	88379	ACT4436-DI
5962-8944708HXA	88379	ACT4487-DI
5962-8944708HXC	88379	ACT4487-DI
5962-8944708HYA	88379	ACT4487-DFI
5962-8944708HYC	88379	ACT4487-DFI
5962-8944708HZA	88379	ACT4436-DFI
5962-8944708HZC	88379	ACT4436-DFI

- 1/ The lead finish shown for each PIN representing a hermetic package is the most readily available from the manufacturer listed for that part. If the desired lead finish is not listed contact the Vendor to determine its availability.
- 2/ Caution. Do not use this number for item acquisition. Items acquired to this number may not satisfy the performance requirements of this drawing.
- 3/ Not available from an approved source. Device type 08 replaces device types 01, 05, and 07.

<u>Vendor CAGE number</u>	<u>Vendor name and address</u>
U4388	C-MAC Microcircuits Limited South Denes Great Yarmouth Norfolk NR30 3PX England
19645	Data Device Corporation 105 Wilbur Place Bohemia, NY 11716-2482
57363	National Hybrid, Incorporated 2200 Smithtown Avenue Ronkonkoma, NY 11779-7359
88379	Aeroflex Laboratories Incorporated 35 South Service Road Plainview, NY 11803-4101

The information contained herein is disseminated for convenience only and the Government assumes no liability whatsoever for any inaccuracies in the information bulletin.